



University of
Massachusetts
Lowell

600 Suffolk Street
Lowell, MA 01854

Center for Atmospheric Research
College of Arts and Sciences

Tel (978) 934-4903
Fax (978) 459-7915
<http://ulcar.uml.edu>

RPI Level 0 Data formats

*A detailed description of the Level 0 data sets and formats
produced by the RPI instrument on the IMAGE satellite*

Revision 2.7

April 5, 2000

Table of Contents

TABLE OF CONTENTS.....	2
TABLE OF ACRONYMS.....	4
LIST OF TABLES.....	5
LIST OF FIGURES.....	6
RPI LEVEL 0 SCIENCE DATA FORMATS.....	7
1 RPI OPERATING MODES, WAVEFORMS, DATABIN FORMATS, AND APIDS	7
1.1 RATIONALE FOR DATA FORMAT DESIGN	7
1.1.1 <i>Databin Types</i>	8
1.2 APID ASSIGNMENT	12
1.3 OPERATING MODES, WAVEFORMS AND DATABIN FORMATS.....	12
1.4 PACKAGE STRUCTURE DESIGN	12
1.4.1 <i>Enumerating databins per frequency</i>	13
1.4.2 <i>Ordering databins per frequency</i>	13
1.4.3 <i>Headers with auxiliary information</i>	15
1.4.4 <i>Filling data section of package</i>	15
2 GENERAL STRUCTURE OF RPI DATA PACKAGE.....	15
2.1 CCSDS PREAMBLE.....	16
2.2 RPI GENERAL HEADER.....	16
2.3 PREFACE.....	16
2.4 DATA HEADER.....	19
2.4.1 <i>Calculation of nominal frequencies</i>	19
2.4.2 <i>Calculation of total number of frequencies</i>	22
2.5 FREQUENCY HEADER.....	23
2.6 DATA SECTION.....	24
2.7 CHECKSUM.....	24
3 CALIBRATION AND CONVERSION OF MEASURED DATA TO PHYSICAL UNITS	25
3.1 ONBOARD DATA PROCESSING	25
<i>Analog signal processing</i>	25
3.1.2 <i>Correcting gain and phase differences of X, Y, and Z receiver channels</i>	28
3.1.3 <i>Default and Dynamic calibration</i>	29
3.1.4 <i>Phase and Amplitude calibration</i>	29
3.1.5 <i>Scaling of X and Y channels</i>	29
3.1.6 <i>Despinning of X and Y channels</i>	30
3.1.7 <i>Digital signal processing</i>	30
3.1.8 <i>Linear-to-log signal compression</i>	30
3.2 CONVERTING RPI READINGS TO PHYSICAL UNITS.....	31
3.2.1 <i>Converting range bin number to km</i>	32
3.2.2 <i>Converting amplitude to field strength in $[nVp/m]$</i>	32
3.2.3 <i>Converting thermal noise amplitudes to $[dBV_{rms}/\sqrt{Hz}]$</i>	35
3.2.4 <i>Converting phase data to physical units</i>	36
3.2.5 <i>Converting Doppler bin number to Hz</i>	36
3.2.6 <i>Converting antenna impedance data to physical units</i>	36
RPI LEVEL 0 HOUSE KEEPING DATA FORMATS	38
4 (R_HK) HOUSE KEEPING DATA SETS. APID = 0X02.....	38
4.1 HOUSEKEEPING HEADER.....	38

4.2	MISCELLANEOUS STATUS INFORMATION.....	39
4.3	DIGITAL SENSOR READINGS	39
4.4	ANALOG SENSOR READINGS.....	40
4.5	NOGO TABLE.....	40
4.6	RPI POWER LIMITS.....	41
5	(R_SRD) SEGMENT REPORT DATA SET. APID=0X04.....	42
5.1	SEGMENT DATA.....	42
6	(R_MSG) SOFTWARE MESSAGE. APID=0X06	42
6.1	SOFTWARE MESSAGE	42
7	(R_ECH) COMMAND ECHO. APID=0X08	44
7.1	COMMAND REPLICA.....	44
	RPI DEVELOPMENT PACKAGE FORMATS	45
8	DEVELOPMENT PACKAGE FORMATS	45
8.1	APID=0X1F FREQUENCY SET RESPONSE PACKAGE.....	45
8.2	APID=0X2F MEMORY READ/WRITE RESPONSE PACKAGE	46
8.3	APID=0X3F VME READ/WRITE RESPONSE PACKAGE.....	46
8.4	APID=0X4F DIGITIZER SAMPLES PACKAGE	47
	APPENDIX A. THERMAL NOISE DATA PROCESSING	48
A1.	CALCULATING LOG AMPLITUDES.....	48
A2.	CALCULATING CROSS POWER TERMS (XY, XZ AND YZ)	49
A3.	CALCULATING CROSS PHASES (XY, XZ AND YZ).....	49
	APPENDIX B. COUPLER BAND CENTER FREQUENCY TABLE.....	50
	APPENDIX C. CALIBRATION PROCEDURES	51
C1.	PHASE CALIBRATION PROCEDURE	51
C2.	ONBOARD CALIBRATION PROCEDURE.....	52
C3.	AMPLITUDE CALIBRATIONPROCEDURE.....	52
C3.1.	<i>Input voltage calculation.....</i>	<i>53</i>
C3.2.	<i>Amplitude calibration coefficients</i>	<i>53</i>
C3.3.	<i>Physical Units table.....</i>	<i>54</i>

Table of Acronyms

ApID	: Application ID (Telemetry Record Type)
BIT	: Built In Test.
CDF	: Common Data Format.
CIDP	: Central Instrument Data Processor
CIT	: Coherent Integration Time
DBD	: Double Byte Data
HKD	: House Keeping Data.
ICD	: Interface Control Document.
IDFS	: Instrument Data File Set
LTD	: Linear Time-domain Data.
LSD	: Linear Science Data
MET	: Mission Elapsed Time
PPS	: Pulses Per Second
PRD	: Precision Range Data.
RMS	: Root Mean Square
RPI	: Radio Plasma Imager
SBD	: Single Byte Data.
S/C	: Spacecraft
SI	: Science Instrument.
SMD	: Spectral Maximum Data.
SPS	: Staggered Pulse Sequence.
SSD	: Standard Science Data.
SST	: Schedule Start Time.
TN	: Thermal Noise.
TPC	: Transmitter Power Card.
TTD	: Thermal Time-domain Data.

List of Tables

<i>Table 1.2-1</i>	<i>ApID Assignment.....</i>	<i>12</i>
<i>Table 1.3-1</i>	<i>Operating Modes, Waveforms and Databin Formats.....</i>	<i>12</i>
<i>Table 1.4-1</i>	<i>Number of databins per 1 frequency.....</i>	<i>13</i>
<i>Table 2.0-1</i>	<i>General Structure of RPI Science Data Package.....</i>	<i>15</i>
<i>Table 2.1-1</i>	<i>CCSDS Preamble, Primary Header.....</i>	<i>16</i>
<i>Table 2.1-2</i>	<i>CCSDS Preamble, Time Tag.....</i>	<i>16</i>
<i>Table 2.2-1</i>	<i>RPI General Header.....</i>	<i>16</i>
<i>Table 2.3-1</i>	<i>Preface.....</i>	<i>17</i>
<i>Table 2.4-1</i>	<i>Data Header.....</i>	<i>19</i>
<i>Table 2.5-1</i>	<i>Frequency Header.....</i>	<i>23</i>
<i>Table 2.7-1</i>	<i>Checksum.....</i>	<i>24</i>
<i>Table 3.1-1</i>	<i>Nominal receiver voltage gains (X, Y, and Z) for various settings of G, in dB relative to the minimum gain at G=1.....</i>	<i>27</i>
<i>Table 3.1-2</i>	<i>Measured receiver voltage gains for various settings of G, in dB relative to the minimum gain at G=1.</i>	<i>27</i>
<i>Table 3.2-1</i>	<i>Physical units for RPI science data.....</i>	<i>32</i>
<i>Table 3.2-2</i>	<i>Doppler shift frequency.....</i>	<i>36</i>
<i>Table 3.2-3</i>	<i>Antenna impedance data in physical units.....</i>	<i>37</i>
<i>Table 4.0-1</i>	<i>RPI House Keeping data format.....</i>	<i>38</i>
<i>Table 4.1-1</i>	<i>HK Header.....</i>	<i>38</i>
<i>Table 4.2-1</i>	<i>Miscellaneous status information.....</i>	<i>39</i>
<i>Table 4.3-1</i>	<i>Digital sensor readings.....</i>	<i>39</i>
<i>Table 4.3-2</i>	<i>Digital Sensor Readings.....</i>	<i>39</i>
<i>Table 4.4-1</i>	<i>Analog sensor readings.....</i>	<i>40</i>
<i>Table 4.5-1</i>	<i>NoGo Table.....</i>	<i>41</i>
<i>Table 4.5-2</i>	<i>Digital and Analog sensor flag parameters.....</i>	<i>41</i>
<i>Table 4.6-1</i>	<i>Peak and Average Power Limits.....</i>	<i>41</i>
<i>Table 5.0-1</i>	<i>RPI Segment Report data format.....</i>	<i>42</i>
<i>Table 5.1-1</i>	<i>Segment Data.....</i>	<i>42</i>
<i>Table 6.0-1</i>	<i>RPI Segment Report data format.....</i>	<i>42</i>
<i>Table 6.1-1</i>	<i>Software message.....</i>	<i>42</i>
<i>Table 6.1-2</i>	<i>Message Codes and Parameters.....</i>	<i>43</i>
<i>Table 7.0-1</i>	<i>RPI Command Echo format.....</i>	<i>44</i>
<i>Table 7.1-1</i>	<i>Command Replica.....</i>	<i>44</i>
<i>Table 8.1-1</i>	<i>Frequency Set Response package, ApID=0x1F.....</i>	<i>45</i>
<i>Table 8.2-1</i>	<i>Memory Read/Write Response package, ApID=0x2F.....</i>	<i>46</i>
<i>Table 8.3-1</i>	<i>VME Read/Write Response package, ApID=0x3F.....</i>	<i>46</i>
<i>Table 8.4-1</i>	<i>Digitizer Sample package, ApID=0x4F.....</i>	<i>47</i>
<i>Table C3-1</i>	<i>X/Y Amplitude Corrections and Physical Units table.....</i>	<i>55</i>

List of Figures

Figure 1.1-1	Linear Time Domain (LTD) databin.....	8
Figure 1.1-2	Spectral Science Data (SSD) databin.....	8
Figure 1.1-3	Spectral Maximum Data (SMD) databin.....	9
Figure 1.1-4.	Precision Group Data (PRD) databin.....	9
Figure 1.1-5	Calibration Data (CAL) databin.....	10
Figure 1.1-6	Double and Single Byte Data (DBD, SBD) databins.....	10
Figure 1.1-7	Thermal-noise Time-domain Data (TTD) databin.....	11
Figure 2.4-1	Example of nominal frequency calculations: linear steps, 4 multiplexed frequencies.....	20
Figure 3.1-2	Three signal processing channels in RPI.	26
Figure 3.1-3	Voltage gain of receivers with preamplifiers for gain $G = 15$	27
Figure 3.1-4	Desired effect of amplitude and phase corrections to X and Y output voltages.	28
Figure 3.2-5	Conversion of amplitudes to physical units.....	33
Figure 3.2-6	Physical units conversion for thermal noise data	35
Figure C1-1	Phase calibration setup with HP synthesizer.....	51
Figure C2-1	Application of calibration signals to X(Y) and Z receiver channels.....	52
Figure C3-1	Amplitude calibration setup with HP synthesizer	53
Figure C3-2	Z channel voltage per digitizer unit, [nV].....	54

RPI Level 0 Science Data Formats

1 RPI Operating Modes, Waveforms, Databin Formats, and APlDs

1.1 Rationale for Data Format Design

RPI is capable of producing data volumes much too high for the telemetry channel throughput. For example, with 5% logarithmic stepping through the nominal frequency band, 128 ranges, 16 repetitions per frequency and 2 polarizations, total data volume collected during a single RPI sounding measurement is

(12 bit in-phase +12 bit quadrature samples) *
3 antennas *
16 Doppler lines *
128 ranges *
2 polarizations
* 142 frequencies = 5,234,688 bytes

With provision of up to 256 Doppler lines, 1024 ranges and smaller frequency steps these volumes may become even larger.

To overcome the problem of high data traffic, a number of measures is devised.

- **Onboard Rice Lossless compression** performed by CIDP.
- **Data thresholding**, which can substantially improve compression ratio.
- **Logarithmic (lossy) compression.** 33% data reduction can be achieved by storing 8 bit logarithmic scale amplitudes and 8 bit phases instead of 12 bit linear scale quadrature components.
- **Storing phase differences instead of absolute phases.** 16% reduction of spectral data per range bin comes from storing two phase differences relative to the third phase instead of three phases of all three antennas.
- **Collapsing of complete spectrum to one Doppler line** by selecting the spectrum peak. This is equivalent to considering only one echo per range.
- **Collapsing three antennae to one antenna** by r.m.s. averaging of amplitudes.

It is not necessary to apply all data reduction measures simultaneously. Only onboard compression of data by CIDP is performed always on all RPI data categories. Data thresholding ratio is specified as a measurement program parameter *Z* (see *RPI Commanding* document, Section 1.4.2, Table 1.4-1) which can be optimally adjusted by RPI flight software to control data volume. Logarithmic compression proved to be efficient for storage of spectral domain data (see Section 1.1.1 below), and in this case phase differences are always stored instead of absolute phases. Collapsing spectrum and antenna data are strong measures affecting amount of science information and should be used with caution.

1.1.1 Databin Types

There is essentially one universal data package format developed for RPI data, which uses different types of a basic measurement unit called a "databin". The databin consists of all measurement data associated with one range/Doppler bin (i.e. log amplitude and phase bytes, or alternately real and imaginary amplitudes for 1 or 3 antennas, Doppler position).

Figure 1.1-1 shows Linear Time Domain (LTD) databin contents. The antenna voltages are sampled twice with 90° phase delay to obtain two 12 bit quadratures per antenna, totaling 9 bytes per databin. The LTD format can be best used for time-domain data (SPS mode, relaxation sounding, chirp sounding).

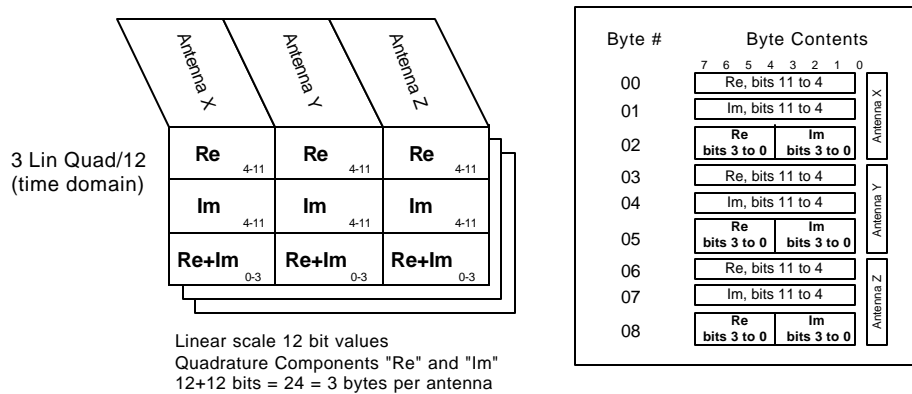

Figure 1.1-1 Linear Time Domain (LTD) databin

A more compact Spectral Science Data (SSD) databin (see Figure 1.1-2) is best suited for storing individual lines of Doppler spectrum.

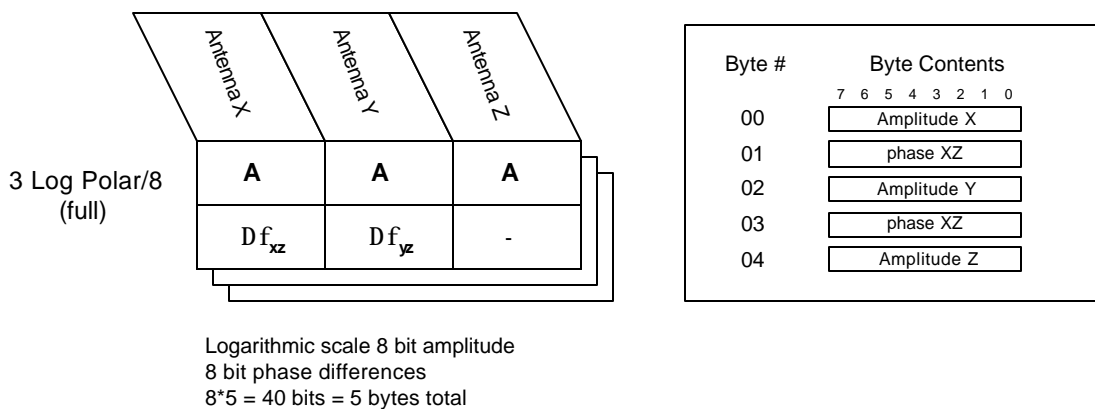

Figure 1.1-2 Spectral Science Data (SSD) databin

SSD databin can be obtained from the LTD databin by:

- converting the quadratures to a “polar” representation (i.e., amplitude and phase),
- reducing them to 8 bits (logarithmic compression for the amplitude), and
- subtracting phase of antenna Z from the all phases.

Collapsing of complete Doppler spectrum to one line requires storing its Doppler number in the output data bin. Corresponding format 3-Log Polar/8-reduced is shown in Figure 1.1-3.

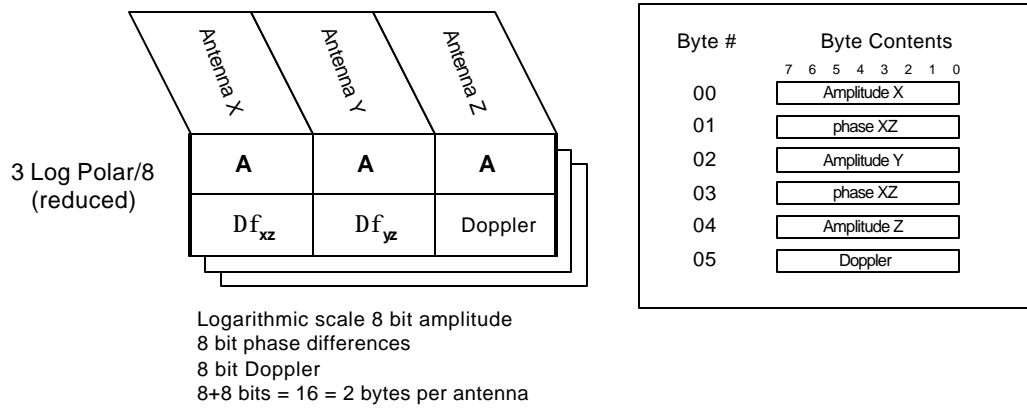

Figure 1.1-3 Spectral Maximum Data (SMD) databin

Precision Group Range technique involves sounding on two closely spaced frequencies with reduction of both frequency data to one Doppler line and calculating phase differences with respect to selected phase on the second frequency. The PRD format (Figure 1.1-4) requires storing three amplitudes, five phase differences and one Doppler line.

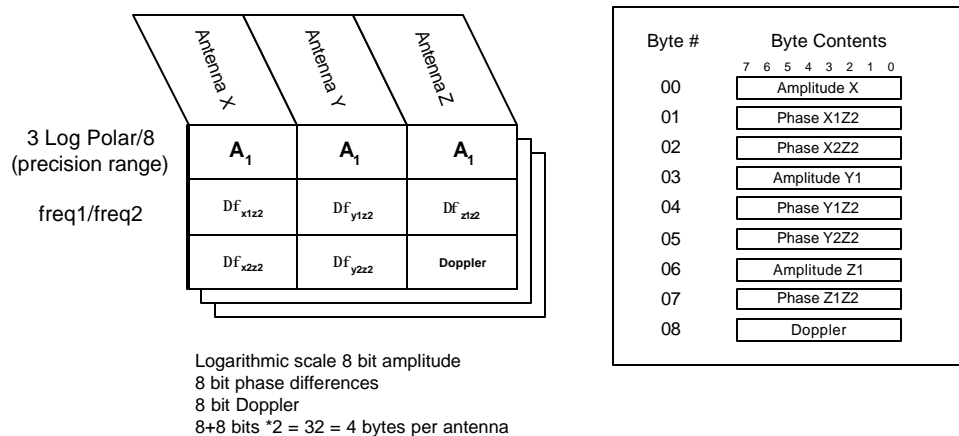

Figure 1.1-4 Precision Group Data (PRD) databin

Figure 1.1-5 shows the databin contents for calibration data, which is very similar to SMD or SSD formats, but stores three amplitudes and three (absolute) phases.

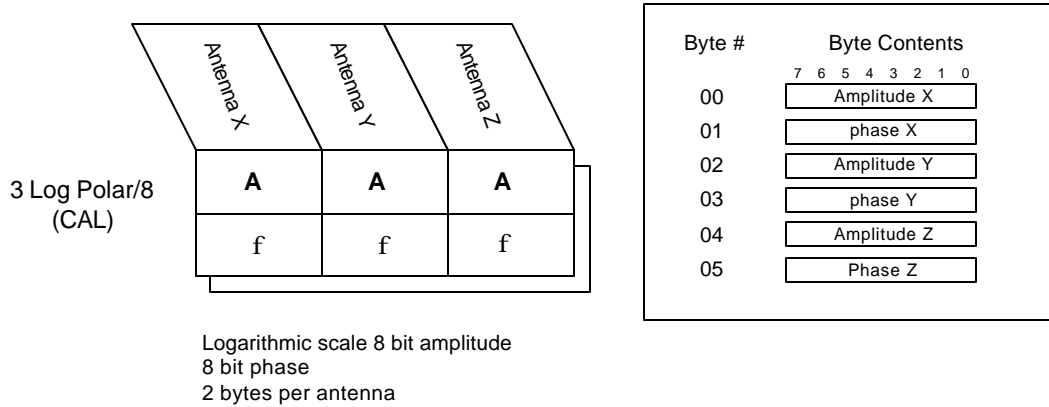

Figure 1.1-5 Calibration Data (CAL) databin

Another two formats are envisioned to store one antenna data, with r.m.s. average amplitude calculated over three antennas. Double Byte Data (DBD) databin stores 1 byte log scale r.m.s. amplitude and 1 byte Doppler number (Figure 1.1-6). SBD (Single Byte Data) databin further reduces resolution of amplitude and Doppler to fit them in 1 byte.

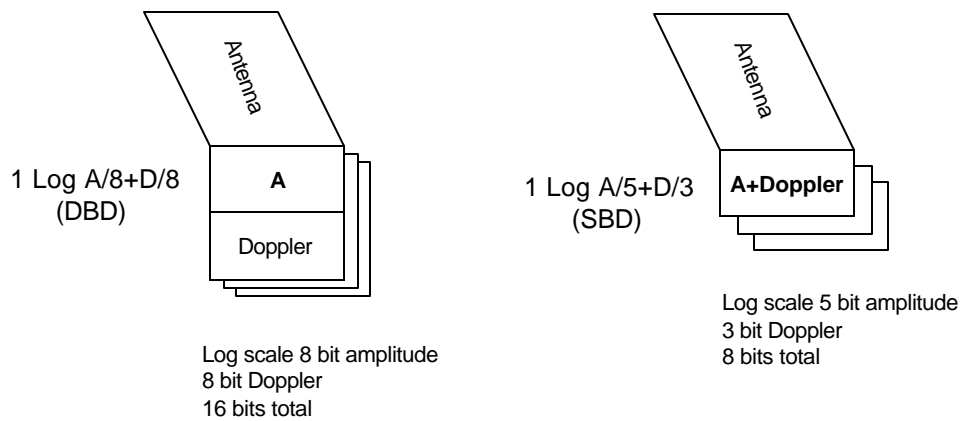

Figure 1.1-6 Double and Single Byte Data (DBD, SBD) databins

Finally, a databin format is provided for the Thermal noise Time-domain Data (TTD). In this measurement mode, the following operations are made for each frequency:

1. For each antenna, $4(2^N)+4$ raw quadrature samples are collected. N is the standard RPI parameter used to specify number of transmitted pulses. No transmission is done

- in the thermal noise mode, and all samples are taken consecutively with 3.2 ms sampling period.
- 2^N averaged log amplitudes are computed using 8-point sliding window with 50% overlay.
 - For each set of 8 averaged amplitudes (36 raw quadrature samples), three cross-power terms are calculated (corresponding to the antenna pairs XY, XZ, and YZ).

Figure 1.1-7 shows the TTD databin layout.

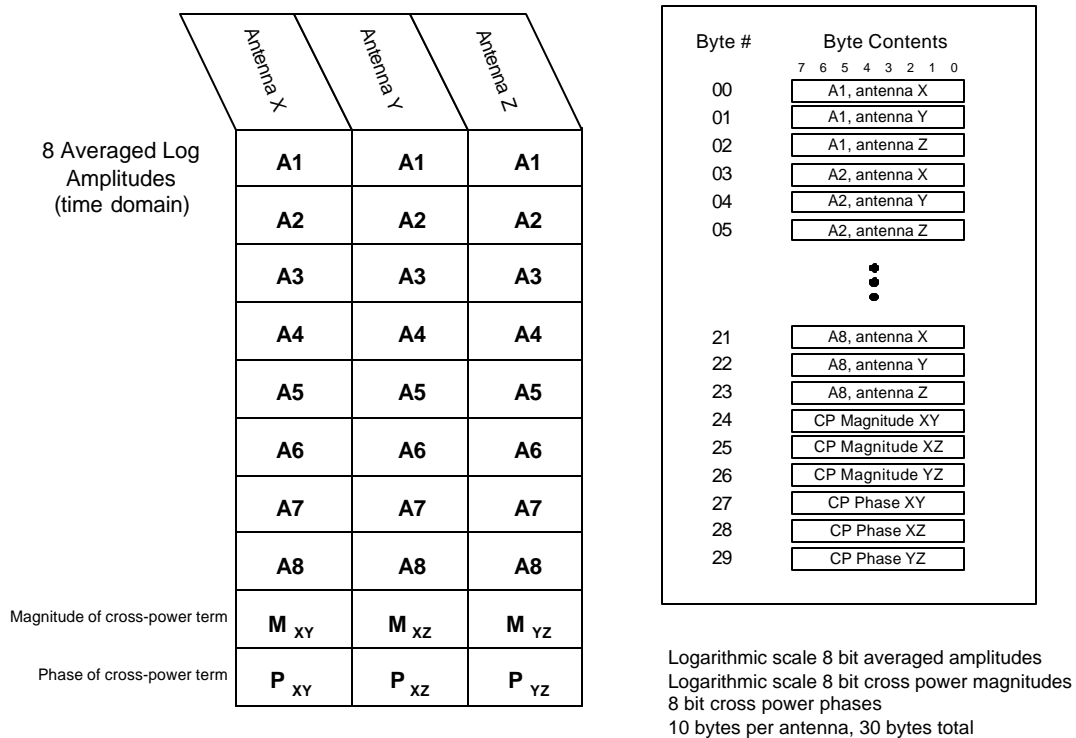

Figure 1.1-7 Thermal-noise Time-domain Data (TTD) databin

One TTD databin accommodates:

- eight averaged amplitudes per antenna, totaling 8 x 3 = 24 logarithmic scale amplitudes, and
- one set of the amplitude and phase of the cross-power terms XY, XZ, and YZ.

Total size of one TTD databin is therefore 24+6 = 30 bytes. Minimum 36 samples (N=3) per antenna have to be collected to produce a good data package with a single TTD databin per frequency. Maximum value of N is 8, with 32 TTD databins per frequency.

A detailed description of onboard thermal noise data processing is given in Appendix A.

1.2 ApID Assignment

Each RPI data package is assigned an ApID, which is selected depending on the Databin format as indicated in Table 1.2-1.

Table 1.2-1 ApID Assignment

Databin	CAL	DBD	LTD	SMD	SBD	PRD	SSD	TTD
Preface [D]	1	2	3	4	5	6	7	8
ApID	0x0C	0x20	0x30	0x40	0x50	0x60	0x70	0x10

There are four types of the science data packages designed to be used during development only. The "development" packages are listed and described in Section 8.

1.3 Operating Modes, Waveforms and Databin Formats

Table 1.3-1 reviews the available choice of RPI scientific data formats, depending on selection of operating mode and waveform.

Table 1.3-1 Operating Modes, Waveforms and Databin Formats

Operating Mode	Waveform	Databin Format	L0.5 Data Format	L1 Data Format
Sounding [O]=S	SPS (X=3)	LTD (D=3)	UDF	CDF Plasmagram
	Chirp (X=2)	DBD (D=2)		
	Complimentary code (X=1,8,9)	LTD (D=3) SMD (D=4)		
	Long pulse (X=4)	SBD (D=5) PRD (D=6)		
	Short pulse (X=5)	SSD (D=7)		
Thermal Noise [O]=T	X=0	TTD (D=8)	UDF	CDF Dynamic Spectrogram
Relaxation [O]=R	Short pulse (X=5)	LTD (D=3)	UDF	CDF Plasmagram
Whistler [O]=W	0.5 sec pulse (X=6)	LTD (D=3)	UDF	CDF Plasmagram
	1.95 sec pulse (X=7)	No output (D=0)	N/A	N/A
Calibration [O]=C	Short pulse (X=5)	CAL (D=8)	UDF	N/A

1.4 Package Structure Design

Arrangement of data into packages imposes two constraints on the data format design:

1. Packages of the same ApID must have a fixed size.
2. Design should be robust to the loss of some packages during transfer.

A provision must be made to store, for each frequency, the following auxiliary information:

1. MET offset from nadir to calculate spin phase
2. Frequency offset obtained during search of the quietest frequency
3. Autogain selection
4. Antenna Impedance data

The size of data collected at a single frequency may vary substantially. In relaxation sounding mode with 8 ranges, 1 polarization, and single byte SBD content total amount of data per frequency is 8 bytes. In a regular sounding with N=5 (32 Doppler lines), 128 ranges, 2 polarizations and 5 byte SSD content the data per frequency amounts to 40,960 bytes. Thus, structuring of data into packages has to account for possible irregular insertion of auxiliary frequency information in the data.

1.4.1 Enumerating databins per frequency

The data format design suggests enumeration of all databin types (Figures 1.1-1 to 1.1-7) collected at a particular frequency. Table 1.4-1 enlists the expected number of databins in various RPI measurement modes and data formats.

Table 1.4-1 Number of databins per 1 frequency

Mode	Waveform	Databin format	Number of databins per 1 frequency
Sounding [O]=S	SPS [X]=3	LTD	# of ranges * # polarizations
	Pulse modes [X]=1,4,5,8,9	LTD	# Doppler lines * # of ranges * # polarizations
		SSD	
		SMD	# of ranges * # polarizations
		DBD	
		SBD	
		PRD	
	Chirp [X]=2	SSD	# Doppler lines * # of ranges * # polarizations
		SMD	# of ranges * # polarizations
		DBD	
SBD			
		LTD	# repetitions * # of ranges * # polarizations
Relaxation [O]=R	Short pulse [X]=5	LTD	# of ranges * # polarizations
Whistler [O]=W	0.5 sec pulse [X]=6		
Calibration [O]=C	Short Pulse [X]=5	CAL	1

1.4.2 Ordering databins per frequency

The order in which the databins are stored is always:

1. Doppler line #1 to 2^N (program parameter N is # of repetitions) (*fastest index*)
2. Range #

3. Polarization

(slowest index)

With this arrangement, for any given databin number it is possible to restore its range bin #, polarization and, if used, Doppler line # or repetition #. The following equations for databin number apply:

$$\tilde{N}_{DB} = \tilde{d} + \tilde{r} \cdot D + \tilde{p} \cdot D \cdot R \quad (1.4-1)$$

where

- \tilde{N}_{DB} = databin number
- D = total number of Doppler lines,
- R = total number of ranges (always assumed 1 for TTD databin)
- \tilde{d} = databin Doppler line
- \tilde{r} = databin range bin number
- \tilde{p} = databin polarization
- \sim means numbering from 0 to $n-1$ instead of 1 to n .

Restoring of databin parameters is done as follows:

$$\tilde{p} = \left\lfloor \frac{\tilde{N}_{DB}}{D \cdot R} \right\rfloor \quad (1.4-2)$$

$$\tilde{n}_{DB} = \tilde{N}_{DB} \bmod (D \cdot R) \quad (1.4-3)$$

$$\tilde{r} = \left\lfloor \frac{\tilde{n}_{DB}}{D} \right\rfloor \quad (1.4-4)$$

$$\tilde{d} = \tilde{n}_{DB} \bmod D \quad (1.4-5)$$

Let's consider the following example:

RPI Sounding, Complimentary Code X=1, SSD databin, 16 Doppler lines, 64 ranges, 2 polarization. Total number of databins per frequency is $16 \cdot 64 \cdot 2 = 2048$. The databin at Doppler line $d = 4$ of 16, range $r = 8$ of 64 and polarization $p = 2$ of 2 has databin serial number, according to (1.3-1),

$$N_{DB} = \tilde{N}_{DB} + 1 = (4 - 1) + (8 - 1) \cdot 64 + (2 - 1) \cdot (8 \cdot 64) + 1 = 1140 \quad (\text{of } 2048)$$

Reverse calculations using (1.3-2 – 1.3-5) give:

$$p = \left\lfloor \frac{1139}{16 \cdot 64} \right\rfloor + 1 = 2 \quad (\text{of } 2)$$

$$\tilde{n}_{DB} = 1139 \bmod 1024 = 115$$

$$r = \tilde{r} + 1 = \left\lfloor \frac{115}{16} \right\rfloor + 1 = 8 \text{ (of 64)}$$

$$d = \tilde{d} + 1 = 115 \text{ mod } 16 + 1 = 4 \text{ (of 16)}$$

1.4.3 Headers with auxiliary information

There are two types of headers designed to store complete per-frequency auxiliary information and ensure proper data handling in case of telemetry loss. A **Data Header** is stored once per package with Frequency reading, MET nadir offset time and databin serial number related to the first databin in the data portion of the package. The Data Header provides information necessary to proceed with data unpacking in case of missing previous telemetry packet. A **Frequency Header** precedes each numerated sequence of databins, containing autogain and frequency search settings, most probable amplitude, and antenna impedance characteristics. The Frequency Header provides necessary per-frequency information.

Detailed description of the headers can be found in Section 2.

1.4.4 Filling data section of package

There is no difference in arrangement of the package for different science data other than contents of the databins. The databins are stored in a package one by one in accordance to the order described in section 1.4.2 (Next Doppler line# - next range – next polarization). The length of data section in packages is fixed at 3072 bytes (to meet the requirement to have fixed package lengths for particular ApID). When the end of the defined 3072 byte data section is reached and no more databins can fit the package, the unused part is zero filled. But, if the end of one frequency is reached before the end of the data block is reached, a frequency header is inserted (again, if there is no room for the frequency header at the end of the data block the block is zero filled). Each new data block contains enough information in the header to identify the first data bin contents, even if the preceding telemetry block is lost.

2 General Structure of RPI Data Package

All Scientific Data Formats have identical general structure of the package as indicated in Table 2.0-1. The structure always includes CCSDS Preamble, General Header, Preface, Data Header, Frequency Header, Data Section, and Checksum.

Table 2.0-1 General Structure of RPI Science Data Package

	RPI Data Block					
Sec_2.1	Sec_2.2	Sec_2.3	Sec_2.4	Sec_2.5	Sec_2.6	Sec_2.7
CCSDS Preamble (12 bytes)	General Header (3 bytes)	Preface (103 bytes)	Data Header (13 bytes)	Frequency Header (10 bytes)	Data Section (3072 bytes)	Checksum (1 byte)

2.1 CCSDS Preamble

The standard CCSDS preamble consists of 6 byte Primary Header and 6 byte Time Tag, as shown in Table 2.1-1 and 2.1-2.

Table 2.1-1 CCSDS Preamble, Primary Header

Byte Count No.	Byte Offset No.	Byte Length	Description	Units	Type	Range
0..1	0..1	2	16 bit ApID data: HHHHHiiiiAAAAAA H- header indicator i – instrument ID A – ApID	N/A	Hex	N/A
2..3	2..3	2	Sequence Counter	N/A	Unsigned short	N/A
4..5	4..5	2	Byte Count	N/A	Unsigned short	0-65535

Table 2.1-2 CCSDS Preamble, Time Tag

Byte Count No.	Byte Offset No.	Byte Length	Description	Units	Type	Range
6..9	6..9	4	MET Coarse Time	100 ms	Unsigned long	0 to 4294967296
10..11	10..11	2	MET Fine Time	195.3125 us	Short	0, 128-65408

2.2 RPI General Header

The general header format is standard for all science data packages. The only difference is in the value content of the ApID. The header identifies the data type, the preface length and the software version number.

Table 2.2-1 RPI General Header

Byte Count No.	Byte Offset No.	Byte Length	Description	Units	Type	Range
12	0	1	Application Identification ApID	N/A	int	exact
13	1	1	Preface length	N/A	int	100
14	2	1	Software Version Number	N/A	int	0-255

2.3 Preface

The “Preface” is standard to for all science data. The Preface (Table 2.3-1) contains the data headers that serve to tag the time/satellite characteristics for each measurement as well as list the required parameters to identify the RPI mode of operation. Unless otherwise specified all values are integers. Note: items in the “description” column that are followed by a bracketed abbreviation (e.g. [L]) correspond exactly to measurement parameters specified in the program parameters in the “Measurement Parameter Table” data (see *RPI Commanding* document, Section 1.4, Table 1.4-1).

Table 2.3-1 Preface

Byte Count No.	Byte Offset No.	Byte Len	Code	Description	Units	Type	Range
15..18	0..3	4		Mission Elapsed Time of last nadir [MET] Stamp.	100 millisec	Long	0 to 4294967296
19	4	1		Schedule #	N/A	Byte	1-32
20	5	1		Program #	N/A	Byte	1-64
21..22	6..7	2	01 (L)	Lower Frequency Limit	1kHz	Short	3kHz-3MHz
23..24	8..9	2	02 (C)	Coarse Frequency If > 0 log steps If < 0 linear steps	1% 100 Hz	Short	1-100% 100Hz-1MHz
25..26	10..11	2	03 (U)	Upper Frequency Limit	1kHz	Short	3kHz-3MHz
27..28	12..13	2	04 (F)	Fine Frequency Step	100 Hz	Short	100Hz-1MHz
29	14.	1	05 (S)	No. of fine steps (no zero value) negative value disables multiplexing	Unit	Byte	+1 to +8 -1 to -8
30..33	15..18	4	06 (X)	Tx Waveform * 0 = no waveform (passive msmt) 1 = Complimentary (51 msec) 2 = FM/CW "Chirp" (125 msec) 3 = Staggered Pulse (786 chips) 4 = Long Pulse (125 msec) 5 = Short Pulse (3.2 msec) 6 = 0.5 sec Pulse 7 = 1.95 sec Pulse 8 = 8 chip complimentary pulse (25 msec) 9 = 4 chip complimentary pulse (13 msec) <i>-1 to -9 same but no phase switching up to four multiplexed waveforms are supported</i>	Table	Four signed bytes	-9 to +9 (no zero value) Each byte contains information on a waveform used in the run
34..37	19..22	4	07 (A)	Tx Antenna options * 1 = Radio Silent (no Tx) 2 = X antenna only 3 = Y antenna only 4 = X+Y in linear polarization 5 = Right Circular Polarization RCP 6 = Left Circular Polarization, LCP 7 = RCP & LCP alternate w.r.t. +Z 8 = X+Y switch linear Pol by 90° <i>-1 to -7 same but bypass antenna coupler</i>	Table	Four signed bytes	-8 to +8 (no zero value)
38..41	23..26	4	08 (N)	No. of Integrated Repetitions * Negative means power integration instead of coherent integration	2 ^N	Four signed bytes	-8 to +8

42..45	27..30	4	09 (R)	Pulse Repetition Rate* 0 = 0.5 pps 1 = 1.0 pps 2 = 2.0 pps 3 = 4.0 pps 10 = 10 pps 20 = 20 pps 50 = 50 pps	Table	Four bytes	0, 1, 2, 4, 10, 20, 50
46-49	31-34	4	10 (O)	Operating Mode* 0 = Standby 1 = Calibration 2 = Relaxation 3 = Sounding 4 = Thermal Noise 5 = Whistler 6 = Test Pattern	Table	Four bytes	0 to 5
50	35	1	11 (W)	Power Limit constraint	Watts	Byte	0-120
51	36	1	12 (E)	Start Range 960 km units	1 Mm	Byte	0 to 255
52	37	1	13 (H)	Range Resolution	10 km	Byte	24 or 48
53..54	38..39	2	14 (M)	No. of range bins 8, 16, 32, 64, 128, 256, 512, 1024	Unit	Byte	8 to 1024
55	40	1	15 (G)	Base Gain negative = Fixed Gain positive = Automatic Gain	Table	Byte	-18 to +18
56	41	1	16 (I)	Frequency Search 0 = Disabled n = 5 freq spaced by n*244 Hz negative = Default calibration positive = Dynamic calibration	Table	Byte	-9 to +9
57..58	42..43	2	17 (P)	No. of ranges stored 1-1024	Unit	Short	1 to 1024
59	44	1	18 (B)	Bottom of range window	1 Mm	Byte	0 to 250Mm
60	45	1	19 (T)	Top of range window	1 Mm	Byte	0 to 250Mm
61..64	46..49	4	20 (D)	Databin Format* 0 = No Data 1 = Calibration – CAL 2 = Double Byte Data – DBD 3 = Linear Time Domain – LTD 4 = Spectral Maximum Data –SMD 5 = Single Byte Data – SBD 6 = Precision Range Data – PRD 7 = Spectral Science Data – SSD 8 = Thermal Time Domain – TTD	Table	Four bytes	0 to 8
65..68	50..53	4	21 (Z)	Threshold cleaning, in % * 0 = no thresholding	%	Four bytes	0 to 99
69-71	54-56	3	22	Spare program parameter			
72	57	1		High RF Noise setting, 0 = no, 1 = yes.	Unit	Byte	0 or 1
73..74	58..59	2		CIT length	10 ms	Byte	0 to 650sec
75	60	1		Number of multiplexed programs	unit	Byte	1
76..77	61..62	2		Data Status Flags	N/A	Short	N/A
78..81	63..66	4		Spin Axis Inertial X component	2s Co.	Int	-1 to +1
82..85	67..70	4		Spin Axis Inertial Y component	2s Co.	Int	-1 to +1
86..89	71..74	4		Spin Axis Inertial Z component	2s Co.	Int	-1 to +1

90..93	75..78	4		Spin Phase Angle	Deg.	Int	-180 to 180
94..97	79..82	4		Filtered Spin Rate Magnitude	R/Min	Int	+/- 21.4748..
98..101	83..86	4		MET Coarse @ which Star Tracker is valid	100 ms	Int	0 to 4294967296
102..105	87..90	4		MET coarse time of periapse passage	100 ms	Int	0 to 4294967296
106..107	91..92	2		Semi -major axis	1 km	Short	0-65535
108..109	93..94	2		Eccentricity, nominally .4	LSB= 3×10^{-5}	Short	0-1
110..111	95..96	2		Cosine of angle of inclination	LSB= 3×10^{-5}	Short	0-1
112..113	97..98	2		Argument of Perigee	LSB= 5.5×10^{-3}	Short	0-360
114..115	99..100	2		Longitude of the Ascending Node	LSB= 5.5×10^{-3}	Short	0-360
116..117	101..102	2		Distance to earth center	1 km	Short	0-65535

* indicates up to four parameters may be packed into four bytes. **The packing order is reversed, i.e., as byte count increases, the program index decreases from 3 to 0.**

2.4 Data Header

The “Data Header” (see Table 2.4-1) contains information necessary to retrieve the databins correctly in case of telemetry losses. See Section 1.4.3 for more details on auxiliary headers design.

Table 2.4-1 Data Header

Byte Count No.	Byte Offset No.	Byte Length	Description	Units	Type	Range
118..119	0..1	2	Frequency step number	unit	Short	1-65535
120..121	2..3	2	Time offset from nadir MET	0.1sec	Short	0 to 6553 sec
122-125	4..7	4	Serial number of the first databin in the package, \tilde{N}_{DB}	unit	Long	0-262143
126-129	8..11	4	Total number of databins per frequency	unit	Long	8-262144
130	12	1	Multiplexed program number	unit	Byte	0-3

2.4.1 Calculation of nominal frequencies

RPI selects the actual frequency for transmission by searching for the quietest frequency around the nominal frequency. To obtain the actual sounding frequency,

- the nominal frequency shall be calculated using the Frequency Step Number stored in the Data Header,
- the frequency search adjustment shall be applied using Frequency Search parameter from the Frequency Header.

The Frequency Step Number is converted to the corresponding nominal frequency in kHz using information stored in the Preface. For **linear frequency stepping**, the nominal frequency is:

$$f_{nom} = [L] + (-[C]) \cdot \left\lfloor \frac{\tilde{N}}{[S]_a} \right\rfloor + [F] \cdot (\tilde{N} \bmod [S]_a), \quad (2.4-1)$$

where

- [L] is Lower Frequency Limit from the Preface,
- [C] is Coarse Frequency Step (reported negative in this case),
- [S]_a is the *absolute value* of Number of Fine Steps,
- [F] is Fine Frequency Step, and
- \tilde{N} is frequency step number from the Data Header.
- $\lfloor \dots \rfloor$ is the *floor* function (the largest integer smaller than the argument)
- mod is *modulo* function (the remainder of integer division).

Example (see Figure 2.4-1):

$$[L] = 100, [C] = -2000 \text{ (i.e., 200 kHz)}, [S] = -4, [F] = 250 \text{ (i.e., 25 kHz)}, \tilde{N} = 15$$

$$f_{nom} = 100 + (200) \left\lfloor \frac{15}{4} \right\rfloor + 25 \cdot (15 \bmod 4) = 100 + 600 + 25 \cdot 3 = 775.0 \text{ kHz}$$

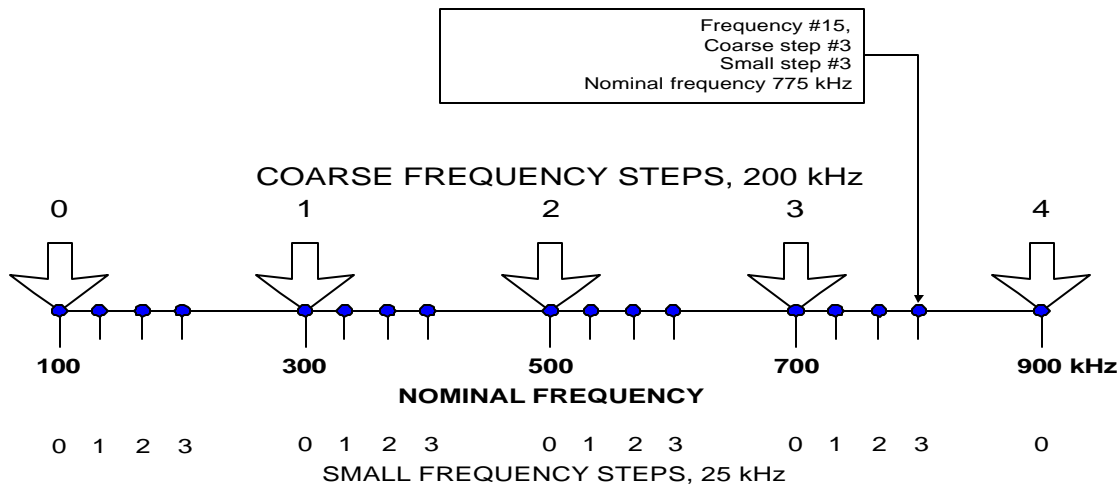

Figure 2.4-1 Example of nominal frequency calculations: linear steps, 4 multiplexed frequencies

For **logarithmic frequency stepping**, the nominal frequency is:

$$f_{nom} = [L] \left(1 + \frac{[C]}{100} \right)^{\left\lfloor \frac{\tilde{N}}{[S]_a} \right\rfloor} + [F] \cdot (\tilde{N} \bmod [S]_a), \quad (2.4-2)$$

where

- [L] is Lower Frequency Limit,
- [C] is Coarse Frequency Step (in %),
- [S]_a is the absolute value of Number of Fine Steps,
- [F] is Fine Frequency Step, and
- \tilde{N} is frequency step number from the Data Header.

The [S] Fine Steps are linearly spaced.

Example 1:

$$[L]=100, [C]=10, [S]=8, [F]=3, \tilde{N} = 23$$

$$f_{nom} = 100 \cdot \left(1 + \frac{10}{100} \right)^{\left\lfloor \frac{23}{8} \right\rfloor} + 3 \cdot (23 \bmod 8) = 100 \cdot 1.1^2 + 3 \cdot 7 = 121 + 21 = 142.0 \text{ kHz}$$

Example 2:

$$[L]=3, [C]=5, [S]=1, [F]=\text{don't care}, \tilde{N} = 100$$

$$f_{nom} = 3 \cdot \left(1 + \frac{5}{100} \right)^{\left\lfloor \frac{100}{1} \right\rfloor} + X \cdot (100 \bmod 1) = 3 \cdot 1.05^{100} + 0 = 394.5 \text{ kHz}$$

Note that is [C] is a multiple of 3 (3, 6, 9, 12...), the frequency stepping is not "logarithmic", but "coupler band centers" (see explanations below).

For **coupler band centers frequency stepping**, i.e., when [C] is a positive multiple of 3 (3, 6, 9, 12...) the nominal frequency is taken from a pre-defined table of frequencies. Each of the table frequencies is the center of a coupler band where the maximum efficiency of the tuned transmission is reached. Table of the coupler central frequencies is given in Appendix B.

To convert the frequency index to nominal frequency for the coupler band centers stepping mode, the following procedure shall be used:

1. Find the table frequency closest to the Lower Frequency Limit, [L]. (The closest table frequency may appear to be lower or higher than [L].) The found frequency, f_{i_0} , will be the first sounding frequency in the measurement, and its index, \tilde{N} , is therefore 0. The index of f_{i_0} in the frequency table will be i_{i_0} .
2. Frequency stepping is then done by incrementing the table index, i_t , from i_{i_0} until the Upper Frequency Limit, [U], is exceeded. The increment to i_t can be greater than 1 if

faster frequency scanning is required. For [C] equal to 3, 6, 9... the increment to the table index is 1, 2, 3..., correspondingly.

Example 1:

$$[L]=100, [C]=6, [S]=1, [F]=\text{don't care}, \tilde{N}=2$$

Closest table frequency to 100 kHz is 100.500 kHz, index #65. As [C] equal to 6, the table will be scanned with index increment of 2, i.e., #65 (100.5 kHz), #67 (105.0 kHz), #69 (111.5 kHz), etc. The frequency with $\tilde{N}=2$ is therefore 111.5 kHz.

For **fixed frequency measurements** (i.e., when [L] is equal to [U]), the nominal frequency is:

$$f_{nom} = [L] + [F] \cdot (\tilde{N} \bmod [S]_a) \quad (2.4-3)$$

where

- [L] is Lower Frequency Limit,
- [S]_a is the absolute value of Number of Fine Steps,
- [F] is Fine Frequency Step, and
- \tilde{N} is frequency step number from the Data Header.

i.e., if no frequency multiplexing is requested (i.e., [S] is 1), all frequencies are equal to [L].

2.4.2 Calculation of total number of frequencies

The total number of frequencies sampled in a single RPI measurement run can be obtained using the following calculations.

For linear frequency stepping, the **total number of frequencies** is:

$$N_{total} = \left(\frac{[U] - [L]}{-[C]} + 1 \right) \cdot [S]_a \quad (2.4-4)$$

where

- [L] is Lower Frequency Limit,
- [U] is Upper Frequency Limit,
- [C] is Coarse Frequency Step, and
- [S]_a is the absolute value of Number of Fine Steps.

For logarithmic frequency stepping, the **total number of frequencies** is:

$$N_{total} = \left\lceil \frac{\log\left(\frac{U}{L}\right)}{\log\left(1 + \frac{[C]}{100}\right)} + 1.999 \right\rceil \cdot [S]_a \quad (2.4-5)$$

For coupler band centers frequency stepping, the total number of frequencies is

$$N_{total} = N_{table} \cdot [S]_a \tag{2.4-6}$$

where N_{table} is number of the coarse frequency steps, which in this case have to be calculated using Table B-1 (Appendix B) containing coupler band center frequencies:

$$N_{table} = \frac{(i_{upper} - i_{lower})}{[C] \left\lfloor \frac{}{3} \right\rfloor} + 1 \tag{2.4-7}$$

where

[C] is Coarse Frequency Step,

i_{upper} and i_{lower} are indices of the Upper Frequency Limit, [U] and Lower Frequency Limit, [L], correspondingly, in the coupler frequency table, found by searching the table frequency closest to the nominal frequency.

For fixed frequency measurements, the total number of different frequencies is $[S]_a$, and transmission is repeated [C] times, hence

$$N_{total} = [C] \cdot [S]_a \tag{2.4-8}$$

2.5 Frequency Header

The format of Frequency Header is shown in Table 2.5.1. See Section 1.4.3 for more details on auxiliary headers' design.

Table 2.5-1 Frequency Header

Byte Count No.	Byte Offset No.	Byte Length	Description	Units	Type	Range
131	0	1	Gain offset from base gain (4 MSB) Frequency Search (4 LSB)	double steps $n \cdot 244\text{Hz}$	Nibble Nibble	0-3 (0,2,4,6 gain steps) 0 to 4
132	1	1	Most probable amplitude	TBD	Byte	TBD
133	2	1	Current on X antenna [Ix]	10mamp	Byte	0-2.55 amp
134	3	1	Voltage on +X dipole antenna [V_{x1}]	10 volt	Byte	0-2550 Volt
135	4	1	Voltage on -X dipole antenna [V_{x2}]	10 volt	Byte	0-2550 Volt
136	5	1	Current on Y antenna [Iy]	10mamp	Byte	0-2.55 amp
137	6	1	Voltage on +Y dipole antenna [V_{y1}]	10 volt	Byte	0-2550 Volt
138	7	1	Voltage on -Y dipole antenna [V_{y2}]	10 volt	Byte	0-2550 Volt
139-140	8-9	2	First Range Bin	Units	Short	0-511

Storing Frequency Header in each data package is excessive if more than one package is required to hold one frequency data, but this measure provides necessary robustness of data format to telemetry data losses.

2.6 Data Section

Data Section contains an array of databins arranged in the sequential order as described in Section 1.4.1 and 1.4.2, possibly with frequency headers. The length of the Data Section is fixed at 3072 bytes.

The Data section can hold more than one frequency data and therefore store Frequency Headers (see Section 2.5 for format description) which separate individual frequency data. One Frequency Header is placed in front of every databin sequence, unless the Data Section begins with the first databin of the frequency and therefore the Frequency Header preceding the Data Section (see Section 2.5) can be used.

The actual frequency setting is not stored in the Frequency Header. To calculate actual frequency of n th frequency data in the package, the *frequency step number* has to be obtained first by adding the frequency step number from the Data Header (see Section 2.4) to n . Then, formulas (2.4-1) or (2.4-2) shall be used to obtain the nominal frequency. Finally, the actual frequency is obtained by applying frequency search correction to the nominal frequency:

$$f_{act}(n) = f_{nom}(n) + (FS - 2) \cdot [I] \cdot 244 \text{ Hz} \quad (2.6-1)$$

where FS is frequency search adjustment value from the Frequency Header, and $[I]$ is Frequency Search parameter from the Preface.

2.7 Checksum

This section contains 1 byte checksum calculated from byte 7 to end of package by successively applying Exclusive-Or operation on the bytes of the package.

Table 2.7-1 Checksum

Byte Count No.	Byte Offset No.	Byte Length	Description	Units	Type	Range
N-1	0	1	Checksum	N/A	Byte	0-255

3 Calibration and conversion of measured data to physical units

3.1 Onboard data processing

Figure 3.1-1 shows a complete diagram of RPI onboard data processing, further detailed in subsequent sections of Chapter 3. For illustration purpose, the diagram indicates an assumed signal of 100 nVp/m in the *x*, *y*, and *z* directions undergoing SSD processing with a gain [*G*] = 15 and operation at a frequency of 65 kHz. To simplify the example, the phase differences of the receivers are not reflected in the processing. The signal phase is assumed 0° so that the in-phase component *I* is equal to the signal amplitude, and the quadrature component *Q* is zero.

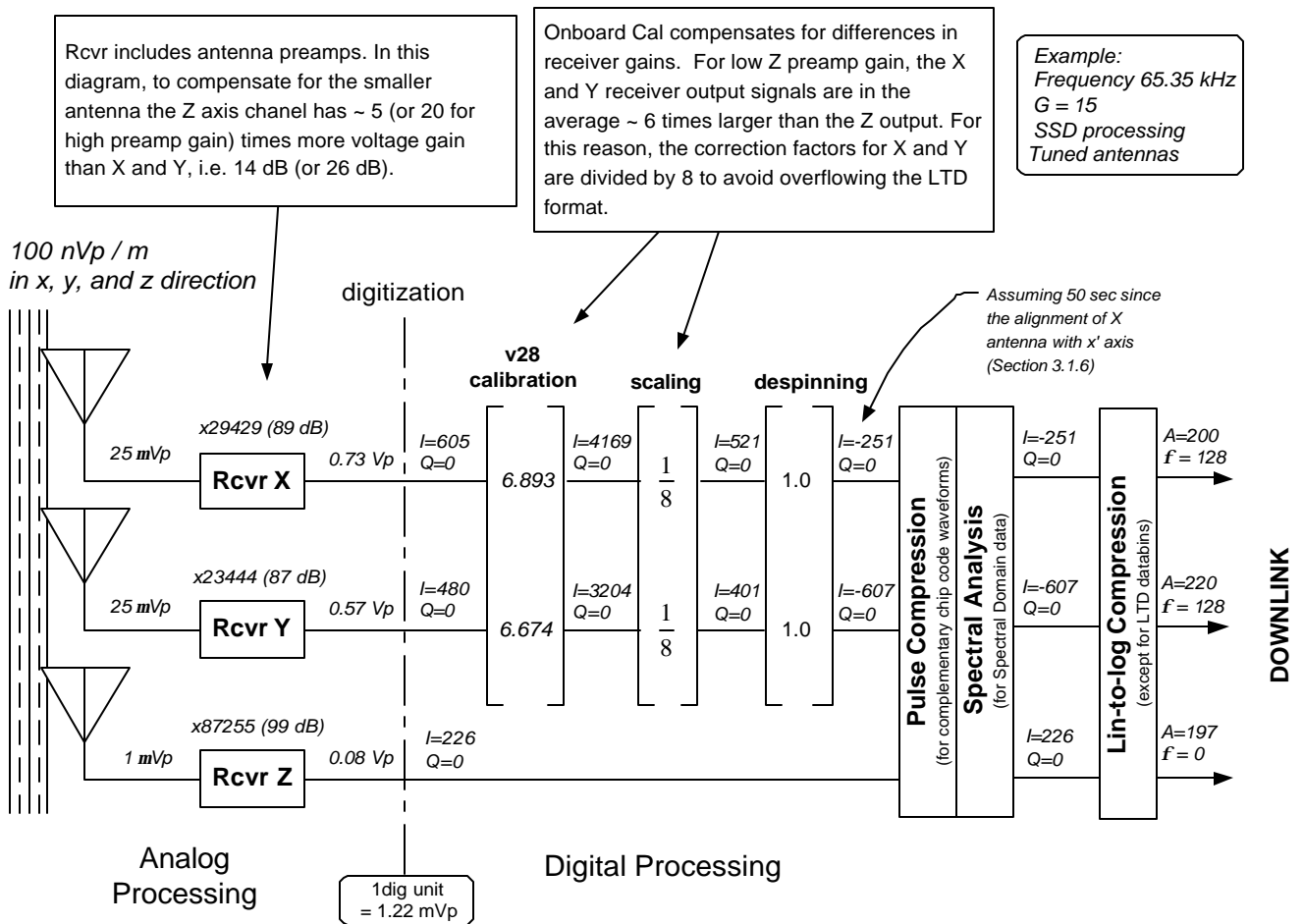

Figure 3.1-1 RPI onboard data processing.

3.1.1 Analog signal processing

Figure 3.1-2 shows the diagram of analog signal processing circuitry of RPI.

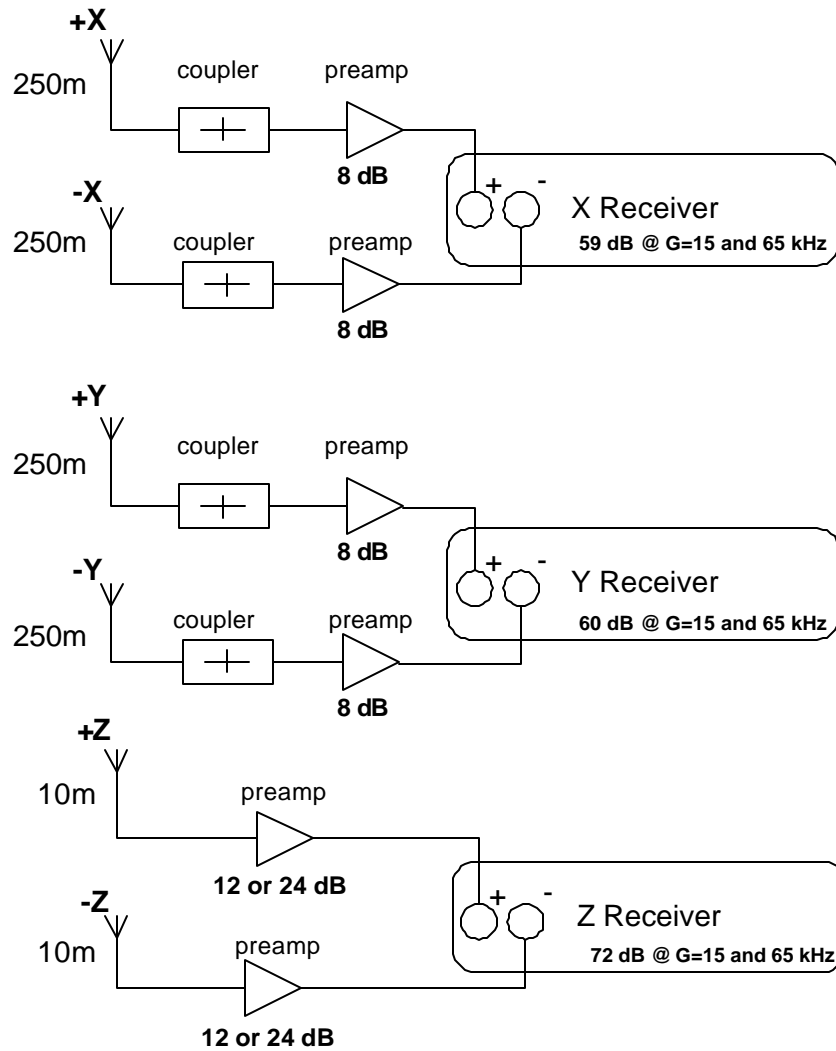

Figure 3.1-2 Three signal processing channels in RPI.

As Figure 3.1-2 indicates, there are two equal channels, X and Y, each connected to a 500 m dipole antenna. Channel Z is provided with a shorter, 20 m antenna, and therefore has to compensate for the smaller input signal¹ by yielding a higher voltage gain. The broadband preamplifiers in the Z channel have 4 dB more gain than the X/Y preamplifiers, and the Z receiver has ~10 dB more gain. This results in a ~14 dB higher gain in Z channel, unless the high gain setting is selected in the Z preamp. In the latter case, the Z channel has ~26 dB more gain.

All receivers have selectable gain that can be set fixed or chosen optimally in the autogain mode. X and Y gain setting are always set identical, the Z gain is typically greater because of the shorter Z antenna. There are 18 different combinations of two gains (Z and

¹ For frequencies below 300 kHz, the difference in the signal voltages induced in the X/Y antennas are $\sim 20 \cdot \log(500/20) = 28$ dB higher than in the Z antenna.

X/Y) that are encoded in a single value of the nominal gain, [G], as shown in Table 3.1-1. The actual gain readings (in dB above the minimum receiver gain) are provided in Table 3.1-2 for the X, Y, and Z channels. The minimum receiver gain is frequency dependent for all receiver channels, and can be derived from the calibration results as discussed below.

Table 3.1-1 Nominal receiver voltage gains (X, Y, and Z) for various settings of G, in dB relative to the minimum gain at G=1.

G	1	2	3	4	5	6	7	8	9	10	11	12	13	14	15	16	17	18
dB steps	0	+6	+12	+18	+24	+30	+24	+30	+36	+42	+48	+54	+24	+30	+36	+42	+48	+54
Z preamp	low	low	low	low	low	low	hi	hi	hi	hi	hi	hi	low	low	low	low	low	low

Table 3.1-2 Measured receiver voltage gains for various settings of G, in dB relative to the minimum gain at G=1.

G	1	2	3	4	5	6	7	8	9	10	11	12	13	14	15	16	17	18
X	0	4.6	10.5	18	24.5	30.7	24.5	30.7	37.1	42.7	49.1	55.5	24.5	30.7	37.1	42.7	49.1	55.5
Y	0	3.8	10.5	20.5	24.4	32.1	24.4	32.1	37.1	47.5	55	60	24.4	32.1	37.1	47.5	55	60
Z	0	5.2	9.3	20.5	23.5	29.7	35.5	40.5	46.7	56.5	61.5	68	23.5	28.5	34.7	44.5	49.5	56

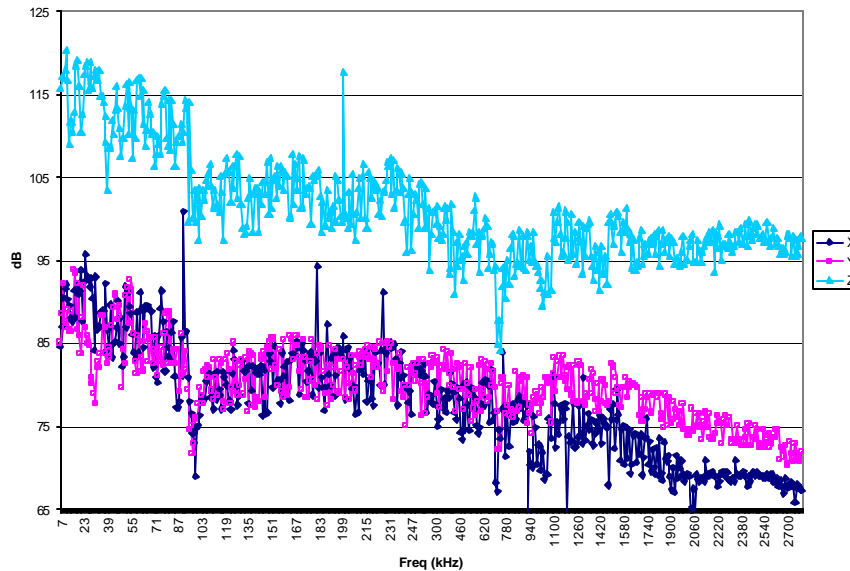

Figure 3.1-3 Voltage gain of receivers with preamplifiers for gain G = 15.

Figure 3.1-3 shows the actual voltage gains in dB of the X, Y, and Z receivers for the gain setting of 15

$$g(f) = 20 \log_{10} \frac{V_{out}(f)}{V_{in}(f)} \tag{3.1-1}$$

where $V_{out}(f)$ is receiver output voltage before the digitizer, and $V_{in}(f)$ is input voltage at the antenna terminals. Using the actual gains for $G=15$ and the table of measured gains relative to the minimum gain (Table 3.1-2), it is possible to calculate the gains for all frequencies and base gain settings.

3.1.2 Correcting gain and phase differences of X, Y, and Z receiver channels

RPI measures the 3 orthogonal components of electric field vectors and derives angle-of-arrival of the echoes reflected from magnetospheric plasma. The signals from each antenna go through individual receiver channels that introduce frequency-dependent amplification and phase shifts. Differences between the channel characteristics would introduce errors to angle-of-arrival calculations, unless corrected. Therefore, calibration of the phase and gain characteristics of the receiver channels assumes vital importance to the angle-of-arrival data validity.

To ensure proper compensation of differences between the receiving channels, RPI introduces phase and amplitude corrections, for each sounding frequency, to the quadrature components measured by the X and Y receivers. Channel Z acts as the amplitude and phase reference and therefore is passed through unchanged. The purpose of introducing the corrections is to obtain identical response of all channels to the input signal. Figure 3.1-4 illustrates the correction process, assuming identical field strengths along the x , y , and z directions.

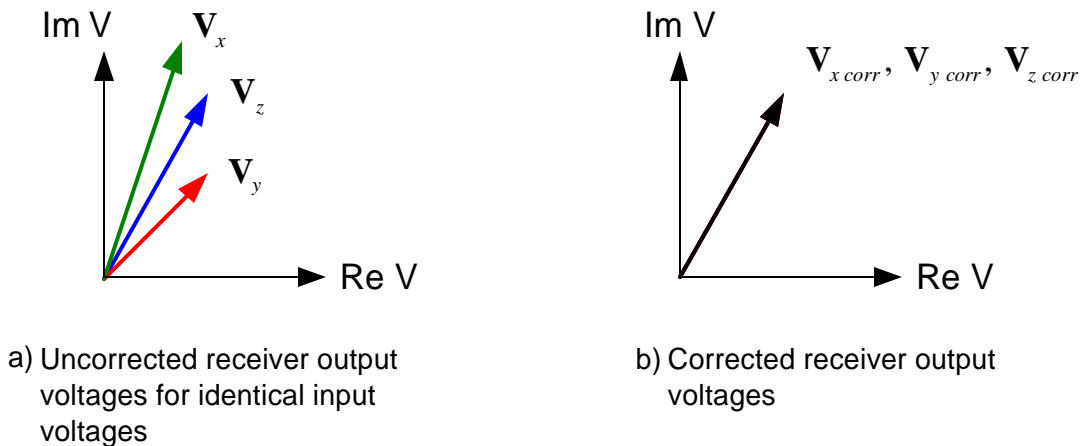

Figure 3.1-4 Desired effect of amplitude and phase corrections to X and Y output voltages.

The correction applied to the X and Y channels makes the outputs identical. The actual correction factors are calculated based on measurements of the voltage gain and phase shifts of the receiver channels.

3.1.3 Default and Dynamic calibration

Two calibration modes are implemented

1. "DEFAULT". A *CAL Table* is stored in the flight software with results of the X, Y, Z channel calibrations obtained in the laboratory (see description of the phase calibration procedure in Appendix C). The key disadvantage of the "default" correction algorithm is its inability to reflect the actual variability of the RPI hardware characteristics with temperature, time, mechanical impacts, etc. during the mission. Also, the CAL Table contains data collected for a particular, predefined set of frequencies, and therefore when the actual sounding frequency does not match any of the frequencies in the default CAL Table, the algorithm has to select the closest available frequency instead.
2. "DYNAMIC": RPI has calibration circuitry that allows the attenuated transmitter signal to go through the receiver channels. The measured receiver response can be directly used to compensate for the inequalities. The dynamic calibration senses the actual receiver characteristics for each sounding frequency immediately before the transmission starts. However, the calibration signals for the X/Y channels are affected by the impedance characteristics of the antennas and therefore the calibration voltages applied at the receiver inputs vary with frequency. A loopback laboratory calibration was conducted to measure the amplitude and phase of the calibration source signal. Further description of the loopback calibration is given in Appendix C.

Either "default" or "dynamic" calibration can be selected in the RPI measurement programs. When dynamic calibration is chosen, it must be combined with the frequency search procedure as both of them are performed during the period of time allocated for the frequency search. Calibration data, regardless of their origin, are reported into the telemetry channel in a data package with ApID = 0x0C. The unified data format (see Section 2) is used to hold calibration data; however, there are no frequency headers in the Data Section of the CAL packets (see section 2.6).

3.1.4 Phase and Amplitude calibration

Gain and phase characteristics of the analog circuitry were studied in laboratory conditions, as described in detail in Appendix C.

3.1.5 Scaling of X and Y channels

For low Z preamp gain, the Z axis channel has ~14 dB more gain than X and Y, but the output signals from the X and Y channels will typically be larger due to the different antenna lengths. An appropriate scaling is required to optimally package all data for telemetry and avoid data storage related saturation of the X and Y readings. The scaling factor of 1/8 is introduced for the X and Y channel data, which has to be removed during ground data processing to return to the case of matched X, Y, Z channels.

3.1.6 Despinning of X and Y channels

After the differences in X and Y channels are removed by calibration, it becomes possible to compensate for the spinning of the X and Y antennas (nominally at 1/2 rpm). The despinning procedure calculates the projection of the E-field vector in the x' , y' , z' system, where

- the x' axis points to the center of the Earth,
- the z' axis, equal to the z axis, points in the direction of the orbital angular momentum, and
- the y' axis is perpendicular to the x' axis in the orbital plane.

The IMAGE spin vector points opposite to the z axis, and therefore the voltages in the primed coordinate system are

$$\begin{aligned} V_{x'} &= V_x \cos 2\pi S t' + V_y \sin 2\pi S t' \\ V_{y'} &= -V_x \sin 2\pi S t' + V_y \cos 2\pi S t' \\ V_{z'} &= V_z \end{aligned} \quad (3.1-2)$$

Here V_x , V_y , V_z are the corrected voltages in the antenna coordinate system, S is the spin rate ($S = 1/120$ sec), and t' is the time measured from the last alignment of the x axis with the x' axis.

3.1.7 Digital signal processing

Certain RPI waveforms require specialized onboard signal processing. The processing includes pulse compression for the complementary phase code sequences, and spectral analysis for equidistant pulse sequences. For the purpose of calibration and conversion of amplitudes to physical units, it is important that the "digital" gain of the signal processing is known.

3.1.8 Linear-to-log signal compression

In order to reduce the telemetry data volume, some of the output data are converted to amplitude/phase representation and logarithmically compressed. The amplitude A_{in} and phase ϕ can be obtained from the in-phase and quadrature samples I and Q using equation (3.1-3):

$$\begin{aligned} A_{in} &= \sqrt{I^2 + Q^2} \\ \mathbf{j} &= \arctg\left(\frac{Q}{I}\right) \end{aligned} \quad (3.1-3)$$

The phase \mathbf{j} is then stored in an 8-bit integer, in linear 360°/255 steps. The amplitude A_{in} is converted to the logarithmic scale and stored in another 8-bit integer:

$$A_{log} = 20 \log_{10}(A_{in}) \cdot C_1 + C_2 \quad (3.1-4)$$

The constants C_1 and C_2 are selected to accommodate the dynamic range of A_{lin} in the 256 levels of A_{log} . The choice of C_1 and C_2 is influenced by the need to minimize real-time computations. By rewriting (3.1-4) as

$$A_{log} = \lceil 10 \log_{10}(I^2 + Q^2) \rceil \cdot C_1 + C_2 \quad (3.1-5)$$

the root function does not have to be calculated. Also, $\log_2()$ function can be used instead of a slower implementation of $\log_{10}()$:

$$A_{log} = 10 \frac{\log_2(I^2 + Q^2)}{\log_2 10} \cdot C_1 + C_2 = 3.0103 \log_2(I^2 + Q^2) \cdot C_1 + C_2 \quad (3.1-6)$$

C_1 shall be then selected to allow enough dynamic range. The 12-bit digitizer produces 12 bit numerical voltage values (11 bits and sign) for I and Q . Assuming that both I and Q are saturated, the maximum A_{lin} is $(2^{11}-1) \cdot \sqrt{2}$. For 4, 8, and 16 chip phase code waveforms, the pulse compression processing (Section 3.1.7) increases the maximum amplitude 4, 8, and 16 times, correspondingly, resulting in $(2^{13}-1) \cdot \sqrt{2}$, $(2^{14}-1) \cdot \sqrt{2}$, and $(2^{15}-1) \cdot \sqrt{2}$ values of the maximum A_{lin} . Therefore, the maximum amplitude to be ever converted to log scale is $32767 \cdot \sqrt{2} = 46340 = 93.32$ dB. Making

$$C_1 = \frac{8}{3.0103} \quad (3.1-7)$$

allows for $255 \cdot 3.0103/8 \sim 96$ dB dynamic range of A_{log} and a convenient formula for A_{log} calculation:

$$A_{log} = 8 \log_2(I^2 + Q^2) + C_2 \quad (3.1-8)$$

To simplify the ground processing, C_2 is selected to always reference the maximum possible value of A_{lin} , for each waveform, to the maximum level of A_{log} (i.e., 255):

$$\begin{aligned} C_2 &= C_3 - C_4 \\ C_3 &= 72.547 \end{aligned} \quad (3.1-9)$$

$$C_4 = \begin{cases} 64, & \text{for 16-chip code} \\ 48, & \text{for 8-chip code} \\ 32, & \text{for 4-chip code} \\ 0, & \text{for all other wave forms} \end{cases}$$

Shifting of the reference level by introducing the waveform-dependent C_4 constant normalizes the DSP gain from the pulse compression (Section 3.1.7) and thus simplifies the log-to-linear decompression algorithm discussed below in the Section 3.2.2.1.

3.2 Converting RPI readings to physical units

Table 3.2-1 shows the choice of physical units for the RPI science data.

Table 3.2-1 Physical units for RPI science data

Measured parameter	Standard units	Stored in the data as	Calibration/Conversion
Nominal Frequency	KHz	Frequency Step Number	Section 2.4.1
Range	Km	Range Bin Number	Section 3.2.1
Field Strength	nVp/m*	12 bit quadrature component	Section 3.2.2
Field Strength	nVp/m*	8 bit log amplitude, except TTD databin	Section 3.2.2
Voltage	dBV/root-Hz	8 bit log amplitude (TTD databin)	Section 3.2.3
Antenna voltage	Vrms	8 bit values in Frequency Header	Section 3.2.6
Antenna current	MA	8 bit values in Frequency Header	Section 3.2.6
Phase	Degrees	8 bit linear phase	Section 3.2.4
Doppler Frequency	Hz	Doppler Bin Number	Section 3.2.5

3.2.1 Converting range bin number to km

The range bin number, \tilde{r} , for a particular databin is obtained using Equation 1.4-4, Section 1.4.2. Then the range in km is

$$R = [E] \cdot 960 + (\tilde{r} + r_{st}) \cdot 10[H] \quad (3.2-1)$$

where

- [E] is Start Range in 960 km units (from Preface)
- \tilde{r} is range bin number
- r_{st} is First Range Bin (from Frequency Header, Table 2.5-1)
- [H] is Range Resolution in 10 km (from Preface), i.e., 24 or 48

3.2.2 Converting amplitude to field strength in [nVp/m]

Figure 3.2-1 details the ground processing steps to convert measured amplitudes from the raw telemetry representation to the field strengths in [nVp/m]. Given example values continue from Figure 3.1-1.

Onboard calibration tables used by the flight software v31 and below have to be replaced by an updated calibration data now available. Before the calibration corrections to the quadrature samples can be removed, un-despinning of the data has to be done. After the new corrections are introduced, despinning has to be reapplied.

3.2.2.1 Log-to-linear decompression

RPI science data with databin formats SSD, SMD, PRD, SBD and DBD (see Section 1.1.1) report 8 bit logarithmically compressed amplitudes. The amplitudes have to be converted back to linear scale before they enter the rest of the conversion process:

$$A_{lin} = 10^{\frac{A_{log} - C_3}{20C_1}} \quad (3.2-2)$$

* RPI received voltages are defined as peak-to-ground, not rms. Vp corresponds to the amplitude of the phasors (the arrows shown in Figure 3.1-3).

where A_{log} is the stored amplitude, and C_1 and C_3 are the compression algorithm constants:

$$C_1 = \frac{8}{3.0103} \tag{3.2-3}$$

$$C_3 = 72.547$$

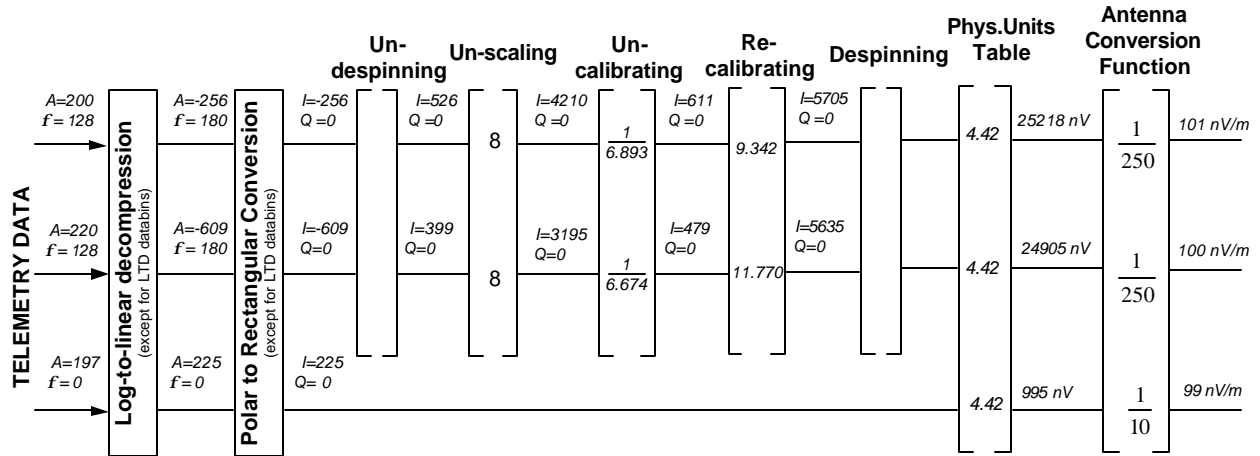

Figure 3.2-5 Conversion of amplitudes to physical units.

3.2.2.2 Polar to Rectangular Conversion

For spectral domain data, the in-phase and quadrature components are restored from the amplitude and phase:

$$I = A_{lin} \cos j$$

$$Q = A_{lin} \sin j \tag{3.2-4}$$

where ϕ is the phase in radians obtained from the 8-bit stored value as discussed below in Section 3.2.4.

3.2.2.3 Un-despinning

The de-spinning procedure (Section 3.1.6) has to be undone before the v28 corrections can be removed. The rotation is done in the opposite direction to de-spinning (3.1-2):

$$V_x = V_{x'} \cos 2pS t' - V_{y'} \sin 2pS t'$$

$$V_y = V_{x'} \sin 2pS t' + V_{y'} \cos 2pS t' \tag{3.2-5}$$

V_x and V_y are the voltages in the antenna coordinate system, S is the spin rate (1/120 sec), and t' is the time measured from the last alignment of the x axis with the x' axis. For all time domain data, t' is the time offset from the nadir, $\Delta T_{nadir}(f)$, stored in Data Header of each telemetry packet. If more than one frequency data fits one packet, $\Delta T_{nadir}(f)$ for the second, third, ... frequency of the packet has to be interpolated (or extrapolated, for the last packet).

For the spectral domain data, 0.5 CIT has to be added to t' (see Section 3.2.5 for CIT calculation). Spin rate magnitude S is stored in the Preface.

3.2.2.4 Un-scaling

All X and Y channel data had been scaled down by a factor of 8 for the purpose of optimal binary data storage (see Section 3.1.5). This factor has to be removed here by multiplying the amplitudes by 8.

3.2.2.5 Removing correction factors

Only amplitude corrections for the flight software v31 and below have to be removed, so the un-calibration procedure is simply:

$$\begin{aligned}
 Q_{x,y} &= \frac{Q_{xc,yc}}{A_{xc,yc}} \\
 I_{x,y} &= \frac{I_{xc,yc}}{A_{xc,yc}}
 \end{aligned}
 \tag{3.2-6}$$

where A_{xc} and A_{yc} are the amplitude corrections introduced by the flight software. The onboard correction factors are reported in the calibration packet as 8-bit log-scale amplitudes and 8-bit phases for the channels X, Y, and Z. A_{xc} and A_{yc} can be restored from CAL packet data using the following formula:

$$A_{xc,yc} = \frac{2 \cdot 8}{1000\sqrt{2}} 10^{\frac{CAL_{x,y} - 72.547}{53.151}} = 0.0113137 \cdot 10^{\frac{CAL_{x,y} - 72.547}{53.151}}
 \tag{3.2-7}$$

where CAL_x and CAL_y are the calibration amplitudes of X and Y channels.

3.2.2.6 Re-calibrating

Re-calibration involves amplitude scaling only, and therefore can be expressed simply as

$$\begin{aligned}
 Q'_{xc,yc} &= Q_{x,y} \cdot A'_{xc,yc} \\
 I'_{xc,yc} &= I_{x,y} \cdot A'_{xc,yc}
 \end{aligned}
 \tag{3.2-8}$$

The table with the new amplitude correction factors A'_{xc} and A'_{yc} can be found in Appendix C, Table C1-1.

3.2.2.7 Despinning

The de-spinning procedure (Section 3.1.6) has to be done after the new corrections are applied, using the equations (3.1-2) and the offset time t' from Section 3.2.2.3.

3.2.2.8 Applying coefficients from the Physical Units Table

The Physical Units Table Each table has coefficients $C_{x,y,z}(f, [G])$ in [nV/unit] for all settings of base gain $[G]$ and selected set of frequencies. The table is derived from the Z channel calibration results obtained during the amplitude calibration at $[G] = 15$ (see

description of the calibration in Appendix C and the coefficient values in Table C3-1). The coefficients for other settings of [G] are obtained using the relative gain data shown in Table 3.1-2:

$$C_{x,y,z}(f, [G]) = C_{x,y,z}(f, 15) \cdot 10^{\frac{C_{x,y,z}(f, 15) - C_{x,y,z}(f, [G])}{20}} \quad (3.2-9)$$

$$C_{x,y}(f, 15) = C_z(f, 15)$$

3.2.2.9 Calculations of field strength

The received field strength, E_R , is proportional to the antenna voltage, V :

$$\vec{E}_R = \frac{1}{L'} \vec{V} \quad (3.2-10)$$

where the proportionality factor L' is the effective antenna length, $L' \approx 0.5L_a$, L_a is the tip-to-tip dipole length. The effective antenna lengths are

$$L'_X = L'_Y = 250m$$

$$L'_Z = 10m \quad (3.2-11)$$

3.2.3 Converting thermal noise amplitudes to [dBV_{rms}/√Hz]

The processing steps to convert thermal noise amplitudes from the raw telemetry representation to [dBV_{rms}/√Hz] are shown in Figure 3.2.2.

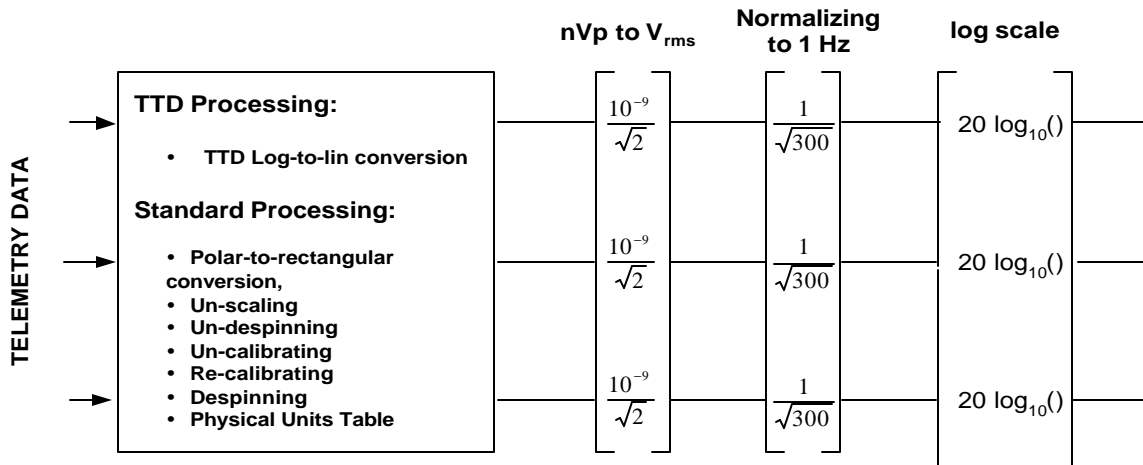

Figure 3.2-6 Physical units conversion for thermal noise data

Logarithmic compression of TTD amplitudes is done differently from the spectral domain data (see Appendix A). To convert TTD amplitudes to the linear scale, the following formula is used:

$$A_{lin} = 10^{\frac{1}{20}(\log(A_{log} + 9.031) - 9.031)} \quad (3.2-12)$$

Un-scaling, un-calibrating, re-calibrating and conversion to nVp is done the same way it is done for other databins. Then nVp are converted to V_{rms} , and then the thermal noise energy collected over the receiver bandwidth of 300 Hz is normalized to 1 Hz, which corresponds to $1/\sqrt{300}$ factor in voltage. Finally, the value is put in dB scale.

3.2.4 Converting phase data to physical units

All phase values given in the RPI data can be converted from 8 bit integer number to 1° units by multiplying them with 360/255.

3.2.5 Converting Doppler bin number to Hz

The coherent integration time is

$$T = \frac{2^{[N]_a} \cdot [S]'}{[R]'} \text{ , [s]} \quad (3.2-13)$$

- [N]_a is absolute value of Number of Repetitions
- [S]' is the Number of Fine Steps, [S], only if it is a positive value, 1 otherwise
- [R]' is Pulse Repetition Rate in pps units; when [R] from Preface is 0, [R]' is 0.5

The Doppler frequency increments are

$$\Delta d = \frac{1}{T} \text{ , [Hz]} \quad (3.2-14)$$

The Doppler frequencies corresponding to the Doppler bin numbers are listed in Table 4.4-1.

Table 3.2-2 Doppler shift frequency

[N]	Doppler bin numbers	Doppler frequencies, Hz
0	1	N/A
1	1-2	$^{-1/2}\Delta d, +^{1/2}\Delta d$
2	1-4	$^{-3/2}\Delta d, -^{1/2}\Delta d, +^{1/2}\Delta d, +^{3/2}\Delta d$
3	1-8	$^{-7/2}\Delta d, -^{5/2}\Delta d, \dots, -^{1/2}\Delta d, +^{1/2}\Delta d, \dots, +^{5/2}\Delta d, +^{7/2}\Delta d$
4	1-16	$^{-15/2}\Delta d, -^{13/2}\Delta d, \dots, -^{1/2}\Delta d, +^{1/2}\Delta d, \dots, +^{13/2}\Delta d, +^{15/2}\Delta d$
5	1-32	$^{-31/2}\Delta d, -^{29/2}\Delta d, \dots, -^{1/2}\Delta d, +^{1/2}\Delta d, \dots, +^{29/2}\Delta d, +^{31/2}\Delta d$
6	1-64	$^{-63/2}\Delta d, -^{61/2}\Delta d, \dots, -^{1/2}\Delta d, +^{1/2}\Delta d, \dots, +^{61/2}\Delta d, +^{63/2}\Delta d$
7	1-128	$^{-127/2}\Delta d, -^{125/2}\Delta d, \dots, -^{1/2}\Delta d, +^{1/2}\Delta d, \dots, +^{125/2}\Delta d, +^{127/2}\Delta d$

3.2.6 Converting antenna impedance data to physical units

Frequency Header contains six 8-bit values from the antenna impedance measurement:

Table 3.2-3 Antenna impedance data in physical units

Measured characteristic	Physical Units	Conversion Polynomial
Current on X antenna [Ix]	mA	$0.017196*x^2+23.697063*x+18.055805$
Voltage on +X dipole antenna [V _{x1}]	V(r.m.s)	$0.001041*x^3-0.079089*x^2+6.833423*x+77.628601$
Voltage on -X dipole antenna [V _{x2}]	V(r.m.s)	$0.000340*x^3-0.072471*x^2+10.139749*x+27.581501$
Current on Y antenna [Iy]	mA	$0.021766*x^2+21.881399*x+15.814330$
Voltage on +Y dipole antenna [V _{y1}]	V(r.m.s)	$0.041969*x^3+3.503154*x+96.108014$
Voltage on =Y dipole antenna [V _{y2}]	V(r.m.s)	$0.039404*x^3+3.459442*x+96.996135$

RPI Level 0 House Keeping Data Formats

The following sections introduce and describe the formats for housekeeping (HK) data produced by the RPI instrument, which include R_HK Housekeeping package with Build-In Test results, R_SRD Segment Report package containing the contents of RPI SRAM segments, R_MSG Software Message package containing software generated message, and R_ECH Command Echo package with a copy of the latest ground command.

4 (R_HK) House Keeping data sets. ApID = 0x02

The RPI house keeping represents the RPI health and safety data package. The R_HK package is generated by RPI to report on system (hardware and software) status. The package is sent periodically (nominally every 10 minutes) or by request from the ground. The structure of the data block is given in sections 5.1 to 5.6. Each section describes part of the data block that is given by the overview in Table 5.0-1.

Table 4.0-1 RPI House Keeping data format

	R_HK Block						
Sec_2.1	Sec_5.1	Sec_5.2	Sec_5.3	Sec_5.4	Sec_5.5	Sec_5.6	Sec_2.5
Data Package Preamble	HK Header	Misc. status info	Digital Sensors	Analog Sensors	NoGo Table	Power Limits	Checksum

4.1 Housekeeping Header

Housekeeping Header format is identical to all four HK packages (R_HK, R_SRD, R_MSG, and R_ECH). It contains five items, as shown in Table 5.1-1.

Table 4.1-1 HK Header

Byte Count Offset	Byte Offset No	Byte Length	Description	Units	Range
7	0	1	Package ApID	N/A	N/A
8	1	1	Software version	N/A	0-255
9..12	2..5	4	CIDP MET stamp	0.1 sec	0 to 4294967296
13..16	6..9	4	RPI MET stamp	0.1 sec	0 to 4294967296
17..18	10..11	2	Argument of perigee	LSB=5.5* 10 ⁻³	0 to 360

Package ApID is preserved for data identification purpose outside the standard data archive environment. Software version is reported for backward compatibility in case of

design changes. CIDP and RPI time stamps are given for the clock comparison purpose. Orbital position phase is given to verify calculation algorithm.

4.2 Miscellaneous status information

This section contains various status information items listed in Table 5.2-1.

Table 4.2-1 Miscellaneous status information

Byte Count Offset	Byte Offset No	Byte Length	Description	Units	Range
19..22	0	4	Last SST in the SST Queue	0.1 sec	0 to 4294967296
23	4	1	Memory checksum failure	N/A	0..1, 1 -failed
24	5	1	Program status (format variable)	N/A	0-255
25	6	1	Communication Status (from serial port UART)	N/A	0-255

4.3 Digital Sensor Readings

This section contains digital sensor readings in accordance with the state of digital I/O lines on the BIT card.

Table 4.3-1 Digital sensor readings

Byte Count Offset	Byte Offset No	Byte Length	Description	Units	Range
26	0	1	Digital sensor readings	N/A	0-255

Each bit of the status byte signifies if reading is valid or not valid. The actual bit readings need to be compared against the expected "Go" value to correctly interpret the result. This comparison is done onboard to fill the NoGo Table where 1 always indicates "NoGo" (and 0 indicates "Go").

The Digital Sensors names and "Go" condition are listed in Table 5.3-2. The following categories of signals are monitored:

- 16MHz RPI master 16 MHz oscillator signal
- Vc Antenna coupler voltages +12 and +24V
- V DC -5, -15 and +15V

Table 4.3-2 Digital Sensor Readings

	D7	D6	D5	D4	D3	D2	D1	D0
Signal name	-	16 MHz	+24 Vc	-	+12Vc	-5V	-15 V	+15 V
GO condition	-	1	1	-	1	0	0	1

Go conditions for digital sensors are specified in the onboard ARMENU control structure, question 351 (see *RPI Commanding* document, Section 2).

4.4 Analog Sensor Readings

This section contains the measurements from the analog input channels on the BIT card. The values are 16 bit integers with 12 bits containing raw value from the ADC.

Table 4.4-1 Analog sensor readings

Byte Count Offset	Byte Offset No	Byte Length	Description	Type	Units	Range
27..28	0..1	2	Channel.00 Xmtr Xb	B	5/4096 V	0-2.5 V
29..30	2..3	2	Channel.01 Xmtr Yb	B	5/4096 V	0-2.5 V
31..32	4..5	2	Channel.02 1st Lob	B	5/4096 V	0-2.5 V
33..34	6..7	2	Channel.03 SysTemp	S	5/4096 V	0-2.5 V
35..36	8..9	2	Channel.04 500 kb	B	5/4096 V	0-2.5 V
37..38	10..11	2	Channel.05 3.84 Mb	S	5/4096 V	0-2.5 V
39..40	12..13	2	Channel.06 95 kb	S	5/4096 V	0-2.5 V
41..42	14..15	2	Channel.07 X+Tmp	B	5/4096 V	0-2.5 V
43..44	16..17	2	Channel.08 X-Tmp	B	5/4096 V	0-2.5 V
45..46	18..19	2	Channel.09 Y+Tmp	S	5/4096 V	0-2.5 V
47..48	20..21	2	Channel.10 Y-Tmp	S	5/4096 V	0-2.5 V
49..50	22..23	2	Channel.11 Ztmp	S	5/4096 V	0-2.5 V
51..52	24..25	2	Channel.12 RFX+	B	5/4096 V	0-2.5 V
53..54	26..27	2	Channel.13 RFX-	B	5/4096 V	0-2.5 V
55..56	28..29	2	Channel.14 RFY+	B	5/4096 V	0-2.5 V
57..58	30..31	2	Channel.15 RFY-	B	5/4096 V	0-2.5 V
59..60	32..33	2	Channel.16 RFSmpZ	B	5/4096 V	0-2.5 V
61..62	34..35	2	Channel.17 RFSmpX	B	5/4096 V	0-2.5 V
63..64	36..37	2	Channel.18 IFSmpZ	B	5/4096 V	0-2.5 V
65..66	38..39	2	Channel.19 IFSmpY	B	5/4096 V	0-2.5 V
67..68	40..41	2	Channel.20 2500 b	S	5/4096 V	0-2.5 V
69..70	42..43	2	Channel.21 400 kb	S	5/4096 V	0-2.5 V
71..72	44..45	2	Channel.22 XvarI	B	5/4096 V	0-2.5 V
73..74	46..47	2	Channel.23 YvarI	B	5/4096 V	0-2.5 V
75..76	48..49	2	Channel.24 YvarV	B	5/4096 V	0-2.5 V

Type B = Burst measurement of a pulse signal must be done during sounding only.

Type S = Single measurement of a continuous signal may be done anytime.

4.5 NoGo Table

This section contains 5 bytes indicating Go/NoGo condition of all sensor readings. Each bit of the NoGo Table bytes is set to 1 (NoGo) if:

- analog sensor reading is outside the onboard red tolerance limits or digital sensor reading is not GO (see Table 5.2-2), and
- the sensor is specified as capable of generating NoGo condition.

Onboard red limits are specified in questions 330-343 of the ARMENU control structure (see *RPI Commanding* document, section 2.1), GO conditions of digital sensors are given in question 351 of the ARMENU structure, and sensors capable of generating NoGo condition are listed in questions 361-365.

Table 4.5-1 NoGo Table

Byte Count Offset	Byte Offset No	Byte Length	Description	Units	Range
77	0	1	Digital Sensor	N/A	0-255
78	1	1	Analog Status : Ch00-Ch07	N/A	0-255
79	2	1	Analog Status : Ch08-Ch15	N/A	0-255
80	3	1	Analog Status : Ch16-Ch23	N/A	0-255
81	4	1	Analog Ch24 and Reserved Bits	N/A	0-255

The Digital and Analog sensor flags and their associated reading parameters are listed in Table 5.5-2.

Table 4.5-2 Digital and Analog sensor flag parameters

Line Count	Category	D7	D6	D5	D4	D3	D2	D1	D0
0	Byte 1 digital	-	16 MHz	+24 Vc	-	+12Vc	-5V	-15 V	+15 V
4	Ch00-Ch07 analog.	XMTR 1	XMTR 2	1 st LO	SysTemp	C140K	3.84M Hz	95kHz	X+tmp
5	Ch08-Ch15 analog.	X-tmp	Y+tmp	Y-tmp	Ztmp	RFX+	RFX-	RFY+	RFY-
6	Ch16-Ch23 analog.	RFSmpZ	RFSmpX	IFSmpZ	IFSmpX	2500 Hz	400 kHz	XvarI	YvarI
7	Reserved	XyvarV	Reserved						

4.6 RPI Power Limits

If necessary, PRI can be instructed to use power limit different from the limit specified in the measurement programs (see program parameter 11(W) in the Preface, Section 2.3). There is a pass-through command R_SYS_PLIM_SET that specifies Peak and Average power limits. Before running a program, RPI evaluates all available limits, and selects the minimum.

The following section of HK package reports current settings of peak and average power limits as instructed from the ground.

Table 4.6-1 Peak and Average Power Limits

Byte Count Offset	Byte Offset No	Byte Length	Description	Units	Range
82	0	1	Peak Power Limit	Watts	0-255
83	1	1	Average Power Limit	Watts	0-255

5 (R_SRD) Segment Report data set. ApID=0x04

This report segment is generated by RPI in response to the ground request R_MEM_DATA_SEND, which instructs RPI to downlink a specific segment of memory from the RPI CPU. The segment can be a section of the flight software or one of the control data structures (Programs, Schedules, SST Tables, ARMENU). The structure of the Segment Report package is given in Table 6.0-1.

Table 5.0-1 RPI Segment Report data format

RPI-SRD Block			
Sec_2.1	Sec_5.1	Sec_6.1	Sec_2.4
Data Package Preamble	HK Header	Segment data	Checksum

5.1 Segment Data

The segment data are stored in accordance to the format described in Table 6.1-1.

Table 5.1-1 Segment Data

Byte Count Offset	Byte Offset No	Byte Length	Description	Units	Range
19..20	0..1	2	SCLen Segment length	N/A	0-65536
21..24	2..5	4	Segment Address	32 bit words	0-0x00FFFFFF
25..SCLen*4+25	3..SCLen*4+3	SCLen*4	Segment Contents	N/A	N/A

6 (R_MSG) Software Message. ApID=0x06

When a software fault is detected, a R_MSG software message package is generated. The message contains a message code (associated with a table for identification of the problem type), and two message parameters. The structure of the Software Message package is given in Table 7.0-1.

Table 6.0-1 RPI Segment Report data format

RPI-MSG Block			
Sec_2.1	Sec_5.1	Sec_7.1	Sec_2.4
Data Package Preamble	HK Header	Software message	Checksum

6.1 Software Message

Table 6.1-1 Software message

Byte Count Offset	Byte Offset	Byte Length	Description	Units	Range
19	0	1	Message Code	Table 7.1-2	0-255
20..23	1..4	4	Message Parameter #1	Table 7.1-2	Message dependent
24..27	5..8	4	Message Parameter #2	Table 7.1-2	Message dependent

Message codes and the associated parameters are listed in Table 7.1-2.

Table 6.1-2 Message Codes and Parameters

Message Code		Message Code Description	Message Parameters Description
202	0xCA	CIT start timeout	#1 -- Timeout, sec
203	0xCB	Pulse start timeout	#1 -- Timeout, sec
204	0xCC	Prerun condition timeout	#1 -- Timeout, sec
205	0xCD	Blank command parameter	#1 -- Command stem
207	0xCF	No timing port signal	
208	0xD0	No 1_PPS signal	
209	0xD1	No Clock Pulse signal	
210	0xD2	Digitizer timeout	#1 -- Timeout, sec
211	0xD3	EEPROM load error	
212	0xD4	EEPROM save error	#1 -- Address, 32 bit
213	0xD5	Data upload checksum error	#1 -- Checksum, 8 bit
214	0xD6	Bad command stem	#1 -- Command stem
215	0xD7	System is not in HiPower to execute command	
216	0xD8	Communications: Unknown Error	
217	0xD9	Communications: Framing Error	
218	0xDA	Communications: Sync. Byte Error	
219	0xDB	Communications: Bad Command Message Checksum	
220	0xDC	Communications: Bad Command Message Header	
221	0xDD	Communications: Bad Command Stem	
222	0xDE	Communications: Bad Upload Checksum	
223	0xDF	Communications: Bad Upload Address	
224	0xE0	Communications: Command Queue Overflow	
225	0xE1	SST Queue Overflow	
226	0xE2	SST Queue Error: MET Already Active	
227	0xE3	SST Queue Error: MET already passed	
228	0xE4	Bad CIDP Data Block Number in Data Load Request	
229	0xE5	Lost Sync. Pulse (Delphi)	

7 (R_ECH) Command Echo. ApiD=0x08

Every command sent to RPI has a corresponding RPI_ECHO package sent back as an acknowledgement. The structure of the Software Message package is given in Table 8.0-1.

Table 7.0-1 RPI Command Echo format

	R_ECH Block		
Sec_2.1	Sec_5.1	Sec_8.1	Sec_2.4
Data Package Preamble	HK Header	Command Replica	Checksum

7.1 Command Replica

Table 7.1-1 Command Replica

Byte Count Offset	Byte Offset No	Byte Length	Description	Units	Range
19	0	1	Command stem	N/A	0-255
20..23	1	4	Command action Parameter 1	N/A	Command specific
24..27	5	4	Command action Parameter 2	N/A	Command specific

RPI Development Package Formats

The following sections introduce and describe the formats for development data packages produced by the RPI instrument in response to debugging commands.

8 Development Package Formats

RPI responds to certain development commands by outputting Development Package(s) to the RS-422 port (to be received by CIDP, GSEOS, ASIST, etc.). All development packages are formatted as standard Science Data Packages, however, they are unlikely to be used during the mission time.

8.1 ApID=0x1F Frequency Set Response Package

The frequency set command R_DEB_FREQ_SET is acknowledged by a message giving the programmed frequency, the coupler mode character, the relay settings for all four couplers, the synthesizer control byte settings, and the preselector control byte setting (see Table 9.1-1).

Table 8.1-1 Frequency Set Response package, ApID=0x1F

Byte No.	Name	Value	Comments
0..2	Sync pattern	FEFA30h	
3	Header	0xDC	Data package
4	ApID	0x1F	
5..6	Byte Count	21	(constant)
7-10	Frequency	f<31:24> f<23:16> f<15:8> f<7:0>	Sounding frequency in Hz.
11	Coupler mode	'N' - normal 'D' - direct 'C' - calibrate 'S' - calibrate-direct	This character indicates whether a special coupler mode has been selected.
12..13	Xplus relays	<15:8> <7:0>	This 16-bit value indicates the states of the 16 relays in this antenna coupler. Bit zero equals 1 if relay K1 is on; bit 1 is 1 for relay K2, etc.
14..15	Xminus relays	<15:8> <7:0>	This 16-bit value indicates the states of the 16 relays in this antenna coupler. Bit zero equals 1 if relay K1 is on; bit 1 is 1 for relay K2, etc.
16..17	Yplus relays	<15:8> <7:0>	This 16-bit value indicates the states of the 16 relays in this antenna coupler. Bit zero equals 1 if relay K1 is on; bit 1 is 1 for relay K2, etc.
18..19	Yminus relays	<15:8> <7:0>	This 16-bit value indicates the states of the 16 relays in this antenna coupler. Bit zero equals 1 if relay K1 is on; bit 1 is 1 for relay K2, etc.
20	Reg5		LO freq = Reg5*125 kHz

21	Reg4		Synth. Control Registers	+ Reg4*125 khz / 2 ⁸ + Reg3*125 kHz / 2 ¹⁶ + Reg2*125 kHz / 2 ²⁴ + Reg1*125 kHz / 2 ³² + Reg0*125 kHz / 2 ⁴⁰
22	Reg3			
23	Reg2			
24	Reg1			
25	Reg0			
26	Data Byte "n"	pfrq	Preselector control byte	
27	Checksum		xor sum bytes 7-26	

8.2 ApID=0x2F Memory Read/Write Response Package

The memory read/write command reply gives the starting and ending addresses of the memory block followed by the contents of the block. The format for the memory read/write command reply message is given in Table 9.2-1.

Table 8.2-1 Memory Read/Write Response package, ApID=0x2F

Byte No.	Name	Byte Value	Comments
0..2	Sync pattern	FEFA30h	
3	Header	0xDC	Data package
4	ApID	0x2F	
5..6	Byte Count		Byte Cnt = 10 + 4*(Addr2-Addr1+1)
7	Data Byte 0	'R' or 'W'	'R' = memory block read, 'W' = memory block write
8..11	Starting Address	<31:24> <23:16> <15:8> <7:0>	Starting address of memory block to be read/written
12..15	Ending Address	<31:24> <23:16> <15:8> <7:0>	Ending address of memory block to be read/written
16..19	Data 1	<31:24> <23:16> <15:8> <7:0>	32 bit word
...
15+4*n		Checksum	xor sum bytes 7-19

8.3 ApID=0x3F VME Read/Write Response Package

The VME Read/Write response package returns the VME address and contents for the affected VME port. The format for the VME read/write command reply message is given in Table 9.3-1.

Table 8.3-1 VME Read/Write Response package, ApID=0x3F

Byte No.	Name	Byte Value	Comments
0..2	Sync pattern	FEFA30h	
3	Header	0xDC	Data package
4	ApID	0x3F	
5..6	Byte Count	6	

7..10	Address	<31:24> <23:16> <15:8> <7:0>	VME Address of affected VME port..
11	Value		Contents of affected VME port after VME Port command is executed.
12	Checksum		xor sum bytes 7-11

8.4 ApID=0x4F Digitizer Samples Package

The R_DEB_DGTZ_GET command continuously takes digitizer samples, sending back digitizer sample blocks as indicated below. Packages are transmitted continuously until RPI receives a new command. The format for the Digitizer Samples package is shown in Table 9.4-1.

Table 8.4-1 Digitizer Sample package, ApID=0x4F

Byte No.	Name	Byte Value	Comments
0..2	Sync pattern	FEFA30h	
3	Header	0xDC	Data package
4	ApID	0x4F	
5..6	Byte Count	4N+1	N = number of complex samples
7..8	Real 1	<15:8> <7:0>	First real sample
9..10	Imaginary 1	<15:8> <7:0>	First imaginary sample
11..12	Real 2	<15:8> <7:0>	Second real sample
13..14	Imaginary 2	<15:8> <7:0>	Second imaginary sample
...
	Real N	<15:8> <7:0>	Nth real sample
	Imaginary N	<15:8> <7:0>	Nth imaginary sample
4N+6	Checksum		xor sum

Appendix A. Thermal Noise Data Processing

Since lots of effort has been put into making standard reusable tools for operational software and data analysis software we would like to find a way to structure the TTD output telemetry packets to use the standard RPI package format (see Section 2). In order to force TTD data into this format, a TTD databin has to be introduced. In the thermal noise mode, RPI produces averaged amplitudes (for each antenna), as well as cross-power and cross-phase terms for each 8 average amplitudes (see Section 1.1 for more details). To avoid paying too dearly in storage efficiency, we have defined the standard TTD databin with 8x3 average amplitudes, 3 cross-power terms, and 3 cross-phase terms, thus making N=3 the minimum value allowed. This requires that we have at least 36 time domains samples per frequency step².

The elements of the TTD databin are 8-bit Logarithmic amplitudes, 8-bit cross-power log amplitudes, and the corresponding cross-power phase arguments also in an 8-bit format (0-359 deg in 1.4deg steps). The algorithm for computing one databin elements uses 36 samples collected on each of three antennas (S_{x1} to S_{x36} , S_{y1} to S_{y36} , and S_{z1} to S_{z36}).

A1. Calculating Log Amplitudes

The goal is to compute 8-point average amplitudes in the logarithmic scale. For the sake of computational efficiency, calculations operate with the power terms. The signal power terms for antenna X, p_{xi} , can be obtained from the complex samples S_i :

$$p_{xi} = I_{xi}^2 + Q_{xi}^2, \quad i = 1..8 \quad (\text{A-1})$$

where I_{xi} is the real (in-phase) component of the sample S_i , and Q_{xi} is the imaginary (quadrature) component of S_i . Note that the power term is always positive, so we can add the terms without concern that anti-phased signals may cancel each other:

$$P_x = \sum_{i=1}^8 p_{xi} \quad (\text{A-2})$$

Averaging and converting to log scale gives the first average amplitude A_x :

$$A_x[1] = 10 \log_{10} \left(\frac{P_x}{8} \right) = 10 \log_{10} P_x - 10 \log_{10} 8 = 10 \log_{10} P_x - 9.031 \quad (\text{A-3})$$

Now move the starting point up 4 samples, and create a new 8-point average which overlaps half the data used in the previous average. Continue up until samples 29 to 36 are used in making the eighth average, the final amplitude to store in the TTD databin.

² For standard sounder modes, all of samples are collected after a single pulse. The TTD mode is a Receive Only mode, so there is no transmitted pulse, but there is still a logic pulse that triggers the digitizer to make a one-dimensional sample array of 32 to 1024 samples at each frequency step.

Repeat for $A_y[1-8]$ and $A_z[1-8]$. Store all $A_{x,y,z}[1]$ to $A_{x,y,z}[8]$ (24 values) in the databin.

A2. Calculating Cross Power Terms (XY, XZ and YZ)

Three complex cross-power terms, W_{xy} , W_{yz} , and W_{xz} , can be calculated from the samples obtained simultaneously from antenna X, Y, and Z:

$$W_{xy} = (I_x + j Q_x) * (I_y - j Q_y) \quad (A-4)$$

$$W_{xz} = (I_x + j Q_x) * (I_z - j Q_z) \quad (A-5)$$

$$W_{yz} = (I_y + j Q_y) * (I_z - j Q_z) \quad (A-6)$$

Conjugating the Y sample in (A-4) gives the cross-power vector, W_{xy} , a phase equal to the phase difference between the X axis and Y axis sample. Since the signals have the receiver calibration corrections as well as the spin-phase rotation correction already performed, the X, Y, and Z signal components are already lined up with the RPI coordinate system, and the combined amplitude of the cross-products is representative of the real E field strengths.

36 samples are used from each of the antennas to obtain 36 sets of power terms W and then calculate the averages:

$$\text{Re}[\langle W_{xy} \rangle] = \frac{1}{36} \sum_{i=1}^{36} \text{Re}[W_{xyi}] \quad (A-7)$$

$$\text{Im}[\langle W_{xy} \rangle] = \frac{1}{36} \sum_{i=1}^{36} \text{Im}[W_{xyi}]$$

These averages are not necessarily positive numbers, and in order to express the magnitude of the cross-power, CP_{XY} , we have to use $\sqrt{\text{Re}^2 + \text{Im}^2}$:

$$CP_{XY} = \sqrt{\text{Re}[\langle W_{xy} \rangle]^2 + \text{Im}[\langle W_{xy} \rangle]^2} \quad (A-8)$$

And in dB,

$$CP_{XY\log} = 10 \log_{10} \left(\text{Re}[\langle W_{xy} \rangle]^2 + \text{Im}[\langle W_{xy} \rangle]^2 \right) \quad (A-9)$$

A3. Calculating Cross Phases (XY, XZ and YZ)

Cross phase term, CPh_{XY} , is calculating as

$$CPh_{XY} = \arctan \left(\frac{\text{Im}[\langle W_{xy} \rangle]}{\text{Re}[\langle W_{xy} \rangle]} \right), \quad [\text{range } -180\text{deg to } +179\text{deg}] \quad (A-10)$$

and stored in [360/255] degree units as 8 bit integer. The terms CPh_{XZ} and CPh_{YZ} are calculated similarly.

Appendix B. Coupler Band Center Frequency Table

Index	Frequency, kHz	Index	Frequency, kHz	Index	Frequency, kHz
0	3.000	46	45.600	92	193.500
1	9.500	47	47.150	93	195.000
2	9.900	48	48.700	94	195.750
3	10.200	49	51.600	95	198.000
4	10.450	50	54.500	96	200.000
5	10.800	51	56.025	97	205.000
6	11.150	52	57.550	98	220.000
7	11.600	53	59.425	99	233.000
8	11.950	54	61.300	100	259.000
9	12.500	55	63.325	101	308.000
10	13.100	56	65.350	102	320.000
11	13.500	57	68.300	103	380.000
12	13.750	58	72.700	104	440.000
13	14.300	59	74.550	105	496.000
14	14.750	60	76.400	106	535.000
15	15.350	61	78.850	107	575.000
16	15.800	62	81.200	108	605.000
17	16.500	63	84.900	109	630.000
18	17.350	64	86.000	110	653.000
19	17.900	65	89.800	111	685.000
20	18.300	66	97.400	112	760.000
21	18.950	67	100.500	113	870.000
22	19.600	68	102.500	114	904.000
23	20.400	69	105.000	115	973.000
24	21.000	70	108.000	116	1190.000
25	21.950	71	111.500	117	1220.000
26	23.000	72	114.000	118	1280.000
27	23.700	73	118.200	119	1320.000
28	24.150	74	134.500	120	1510.000
29	25.050	75	137.500	121	1600.000
30	25.900	76	139.750	122	2000.000
31	26.900	77	143.500	123	3000.000
32	27.700	78	146.000		
33	28.900	79	149.500		
34	30.600	80	151.500		
35	31.600	81	154.500		
36	32.300	82	172.000		
37	33.500	83	174.000		
38	34.500	84	175.500		
39	35.900	85	177.000		
40	37.000	86	180.000		
41	38.700	87	182.500		
42	40.400	88	185.000		
43	41.600	89	186.000		
44	42.550	90	190.500		
45	44.075	91	192.000		

Appendix C. Calibration Procedures

C1. Phase calibration procedure

Phase calibration was done at SwRI labs by feeding a known generator signal into three receivers set at $G=15$, as shown on Figure C1-1.

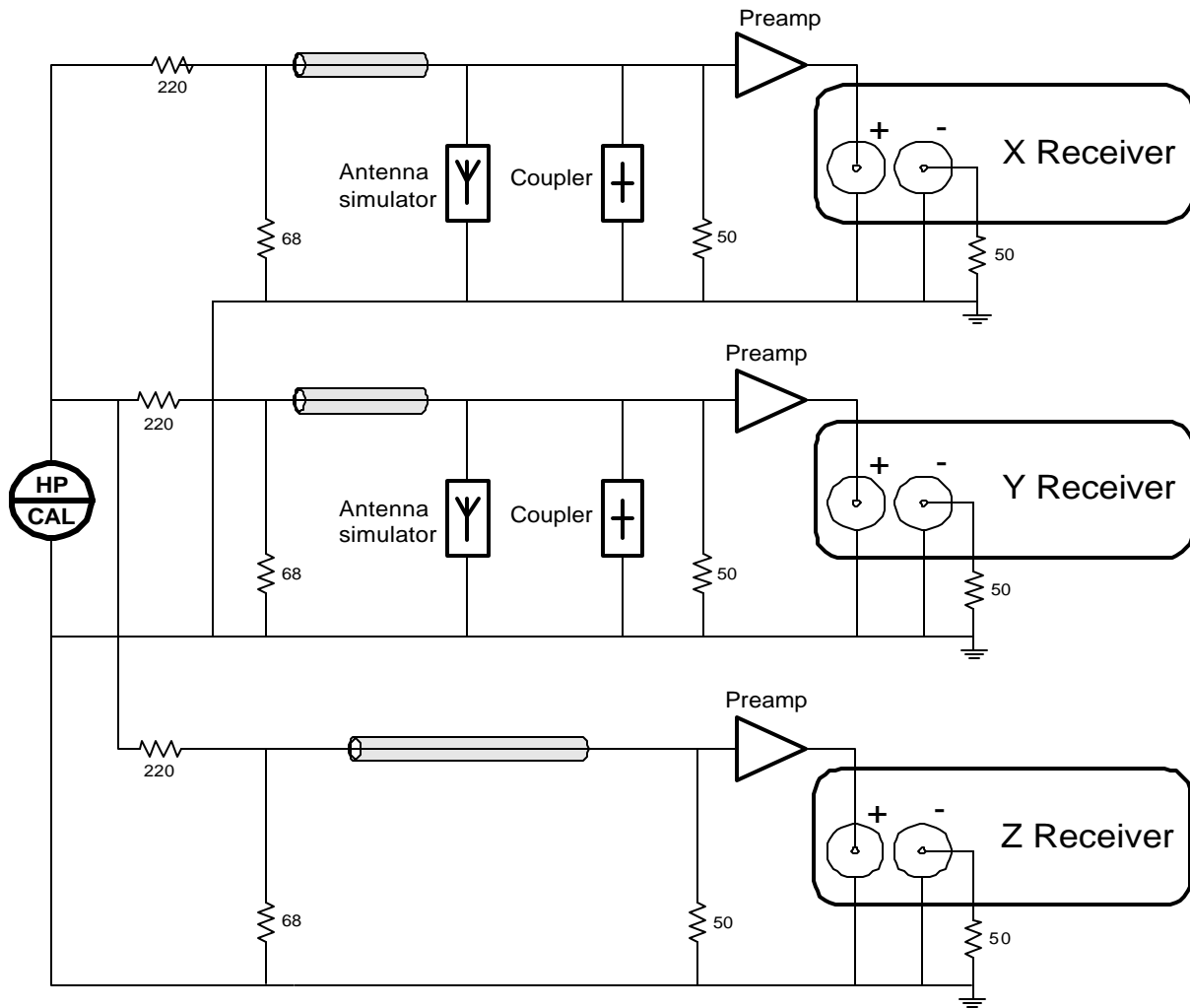

Figure C1-1 Phase calibration setup with HP synthesizer

The output of each receiver was sampled twice, to capture I and Q quadrature components spaced 90° apart. The ratio of Z channel output to X and Y channels comprises the default calibration table.

C2. Onboard calibration procedure

Onboard calibration procedure is done by feeding identical calibration signals to the receivers on each frequency before the actual transmission is made, as shown in Figure C2-1. The calibration signal is applied directly to the couplers at the base of the X and Y antennas; however, the Z channel is calibrated without the wide-band pre-amplifiers whose gain is assumed equal to 12 dB (LoGain setting) and phase contributions are assumed constant for the mission period. The amplitude of the calibration signals is always the same and is selected optimally to obtain good receiver responses with any setting of their gain.

The receiver response to the calibration signals is used onboard to introduce corrections to the X and Y channel data that equalize their phase and gain characteristics with the Z channel. It is important to make +12 dB corrections to the X and Y data on the ground if HiGain setting was used for the Z preamplifier. With this correction introduced, RPI data can be directly used to derive the angles of arrival. An additional effort is required to convert the observed amplitudes to the physical units, [n^V/m], as discussed in Section 3.2.1.

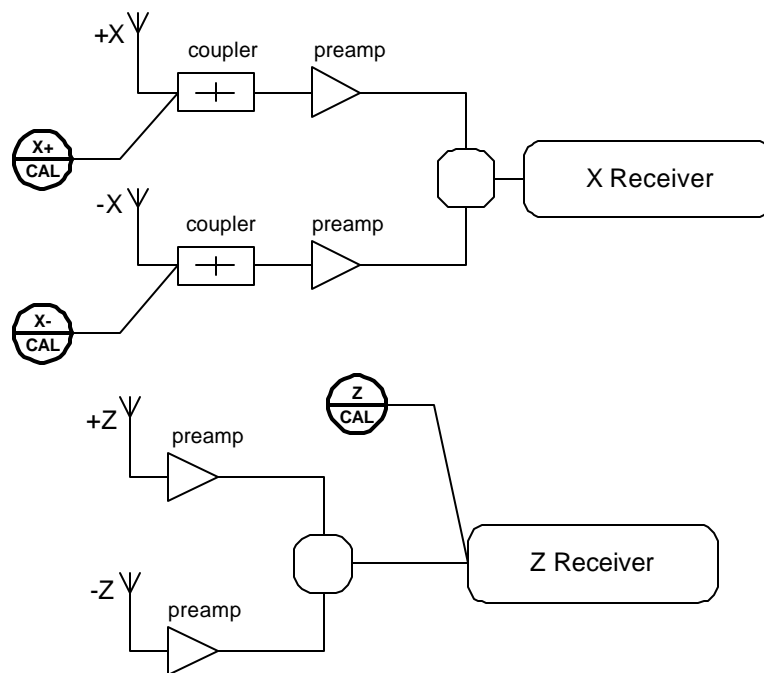

Figure C2-1 Application of calibration signals to X(Y) and Z receiver channels

C3. Amplitude calibration procedure

Amplitude calibration was done at SwRI labs by feeding a known generator signal into receiver as shown on Figure C3-1.

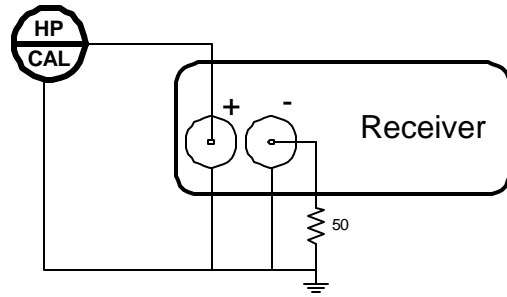

Figure C3-1 Amplitude calibration setup with HP synthesizer

C3.1. Input voltage calculation

The generator input was originally expressed in [dBm into a 50 ohm load]. The following considerations are used to express the input voltage in [Vp]:

- dBm units are referenced to 1 mW of power on 50 ohm load
- Voltage corresponding to 1 mW on 50 ohm is:

$$V_{ref,rms} = \sqrt{1 \text{ mW} \cdot 50 \text{ ohm}} = \sqrt{0.05} \text{ [V]}$$

$$V_{ref,p} = \sqrt{2} V_{ref,rms} = \sqrt{2} \sqrt{0.05} \text{ [V]} = \sqrt{0.1} \text{ [V]}$$

- For D dBm the generator output voltage is

$$V_{g-out,p} = V_{ref,p} * 10^{(D/20)} = \sqrt{0.1} * 10^{(D/20)} \text{ [V]}$$

To account for the fact that the calibration setup (Figure C1-1) is different from the operational RPI setup where both dipole elements feed the receiver, 6 dB are subtracted from the test source power. Another 6 dB are subtracted to account for the losses in the 3 way splitter. Thus, the input voltage for this test is

$$V_{in,p} = \sqrt{0.1} * 10^{\frac{D-12}{20}} \text{ [V]}$$

To obtain the value of receiver sensitivity in volts per digitizer unit, $S_{du,p}(f)$, from the amplitude calibration data, the following formula is used:

$$S_{du,p}(f) = \frac{V_{in,p}}{D_{out}(f)} \text{ [V/unit]},$$

where $D_{out}(f)$ are the amplitudes [in digitizer units] and $V_{in,p}$ is the peak voltage in [V].

C3.2. Amplitude calibration coefficients

Ratio of Z channel amplitudes to X and Y channel amplitudes gives the correction coefficients A'_{xc} and A'_{yc} for the re-calibration procedure described in Section 3.2.2.6. The coefficients are given in the Table C3-1.

C3.3. Physical Units table

Figure C3-1 shows graph of the Z channel zero-to-peak voltage per digitizer unit, in [nV/unit], which is used for conversion of the amplitudes to physical units in Section 3.2.2.8.

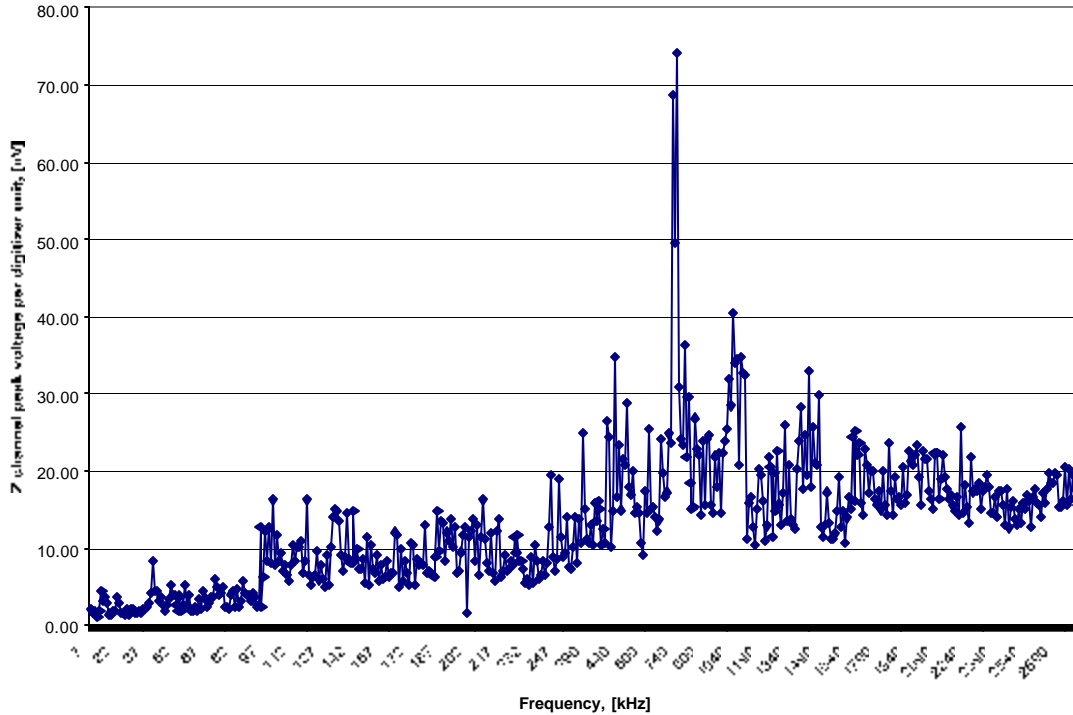

Figure C3-2 Z channel voltage per digitizer unit, [nV].

The gains of the X and Y channels are matched to the gain of the Z receiver during onboard calibration (see Section 3.1.2) so that, for the purpose of conversion to physical units, X and Y digitizer unit values are not used. The zero-to-peak voltage [in nV] per digitizer units for Z channel are given in Table C3-1. Section 3.2.2.3 explains how to use these coefficients to derive the Physical Units table for all channels and all settings of the base gain.

Table C3-1 X/Y Amplitude Corrections and Physical Units table.

Frequency [kHz]	Correction coefficient A'_{xc}	Correction coefficient A'_{yc}	Voltage per digitizer unit [nVp]
7	36.786	34.606	1.971
8	32.217	27.144	1.691
9	21.343	17.426	1.712
10	20.693	36.123	1.549
11	26.149	44.490	1.168
12	20.990	24.373	1.777
13	9.402	13.094	4.328
14	15.622	18.961	3.123
15	13.994	12.361	3.653
16	11.783	8.955	2.784
17	33.190	17.836	1.448
18	22.553	42.523	1.343
19	17.918	15.358	1.933
20	16.976	31.871	1.961
21	6.800	21.410	3.704
22	17.677	16.946	2.885
23	17.989	19.127	1.632
24	13.724	37.506	1.466
25	19.310	49.934	1.404
26	13.823	30.128	2.058
27	23.085	52.569	1.368
28	14.056	60.605	1.991
29	18.772	57.071	1.976
30	45.052	81.761	1.694
31	17.635	103.667	1.546
32	31.611	50.388	1.781
33	34.732	62.367	1.564
34	20.254	36.133	2.218
35	19.757	21.180	2.212
36	18.400	19.822	2.398
37	26.678	19.183	2.896
38	7.088	19.022	4.213
39	6.840	10.953	8.295
40	15.872	16.209	4.524
41	9.065	18.823	4.449
42	27.071	17.596	3.110
43	18.585	11.252	3.721
44	24.816	12.849	2.699
45	28.564	18.269	1.937
46	14.459	18.870	2.619
47	20.235	11.917	3.418
48	9.354	9.119	5.137
49	23.868	32.905	3.942
50	21.188	19.133	3.923
51	12.420	36.054	2.520
52	29.292	19.059	1.887
53	8.975	8.446	3.774
54	22.224	28.051	1.856

55	17.610	11.222	2.577
56	11.562	6.374	5.239
57	29.261	22.636	2.672
58	21.563	22.680	3.942
59	25.213	59.568	1.785
60	45.268	35.479	1.742
61	15.244	45.731	2.230
62	24.538	48.890	1.739
63	13.188	30.593	3.304
64	35.684	33.205	2.042
65	9.342	11.769	4.424
66	11.581	16.730	3.539
67	17.590	36.974	2.428
68	15.297	22.594	2.854
69	11.875	17.102	3.738
70	25.838	25.037	3.704
71	10.403	12.801	5.942
72	22.157	12.810	4.977
73	30.716	27.777	3.865
74	14.420	18.720	4.281
75	8.577	17.863	4.946
76	13.445	30.042	2.465
77	22.596	41.567	2.249
78	49.523	29.462	2.037
79	14.400	11.364	4.022
80	16.653	10.077	4.375
81	34.891	39.038	2.356
82	18.386	9.488	4.740
83	25.315	39.431	2.342
84	15.746	23.405	3.250
85	18.788	15.823	5.812
86	40.319	18.063	4.169
87	43.113	19.452	3.884
88	39.570	34.594	3.884
89	19.636	33.790	3.224
90	25.350	14.358	4.236
91	3.019	29.121	3.670
92	25.115	33.200	2.315
93	21.976	37.368	2.645
94	8.724	10.383	12.639
95	63.335	93.084	2.435
96	29.208	34.685	6.221
97	19.591	26.168	12.251
98	32.935	33.748	8.209
99	34.474	15.712	12.639
100	27.344	24.015	8.125
101	13.214	9.863	16.251
102	23.919	16.358	7.884
103	12.607	12.284	11.710
104	17.867	19.526	8.209
105	16.077	10.988	9.368
106	16.228	13.966	7.110
107	12.299	14.229	7.731

108	15.828	14.383	6.474
109	25.354	17.031	5.729
110	17.699	17.278	7.731
111	16.565	14.466	10.341
112	12.685	10.554	8.209
113	14.753	10.991	10.209
114	10.074	14.180	10.080
115	11.926	7.943	10.908
116	21.001	12.682	6.806
117	20.359	10.752	8.382
118	6.305	9.523	16.251
119	16.798	26.434	6.581
120	23.307	16.712	5.204
121	19.995	12.782	6.270
122	23.611	15.531	6.422
123	18.062	16.589	9.594
124	17.703	21.532	5.855
125	9.714	8.704	7.884
126	14.386	22.749	5.942
127	25.434	18.045	4.915
128	17.767	15.616	9.153
129	28.002	24.155	5.104
130	8.663	9.238	10.080
131	6.312	6.178	13.970
132	6.728	9.394	15.024
133	6.933	7.804	14.746
134	7.136	6.298	13.496
135	17.465	19.682	9.049
136	13.504	11.332	6.924
137	15.085	9.126	8.750
138	6.499	11.481	14.478
139	11.321	9.636	8.562
140	12.798	20.977	8.043
141	13.108	18.182	7.963
142	6.574	9.818	14.746
143	12.421	18.075	8.562
144	9.433	8.350	9.954
145	25.469	11.797	7.373
146	13.652	10.816	7.305
147	21.252	16.727	8.655
148	32.431	13.486	5.492
149	6.883	6.569	11.540
150	16.721	12.934	5.273
151	6.155	6.172	10.477
152	17.773	13.965	7.174
153	10.568	9.557	6.806
154	13.076	10.216	9.153
155	19.648	21.449	5.812
156	14.772	9.907	7.731
157	26.792	12.853	5.898
158	12.733	21.769	6.173
159	13.038	8.004	8.295
160	15.014	23.208	6.320

161	21.317	20.401	6.748
162	13.308	21.225	6.691
163	12.567	10.689	12.065
164	7.428	5.338	11.710
165	15.918	13.064	5.008
166	8.476	8.772	9.954
167	14.371	12.777	5.647
168	8.184	7.510	8.209
169	10.648	10.248	6.865
170	27.222	19.983	5.104
171	6.976	8.006	10.617
172	6.718	12.690	10.341
173	14.378	12.360	5.309
174	10.088	9.784	8.655
175	14.863	18.483	7.884
176	12.483	18.235	8.043
177	10.726	14.817	7.807
178	6.011	6.876	13.054
179	20.914	9.667	6.748
180	12.001	16.022	7.110
181	12.981	18.420	6.806
182	3.598	12.192	6.527
183	20.221	24.183	6.270
184	8.837	8.129	8.848
185	7.423	5.022	14.746
186	13.141	7.956	9.594
187	12.939	7.524	13.496
188	9.553	10.438	13.271
189	6.351	11.512	8.295
190	8.857	13.676	12.065
191	11.366	6.615	10.908
192	6.168	10.970	13.729
193	7.907	12.212	10.209
194	11.308	7.620	12.639
195	15.911	11.273	6.748
196	10.366	12.281	7.110
197	7.774	14.434	9.480
198	6.820	11.903	11.710
199	6.612	8.034	12.639
200	39.178	53.870	1.602
201	13.195	12.727	11.375
202	6.252	7.386	12.251
203	5.333	7.015	13.729
204	11.540	14.550	8.382
205	6.451	11.460	13.054
206	19.874	12.594	6.527
207	10.833	9.087	11.540
208	11.365	8.220	16.251
209	11.273	8.372	11.215
210	22.545	10.323	7.963
211	14.340	11.332	6.924
212	6.980	7.098	11.885
213	14.365	13.972	6.748

214	18.743	14.399	5.688
215	6.263	6.066	12.251
216	11.234	6.054	13.729
217	17.927	11.291	6.370
218	16.620	12.561	6.924
219	16.209	12.157	9.049
220	10.645	10.417	7.110
221	22.216	13.233	7.373
222	9.361	9.140	8.295
223	11.781	11.733	7.807
224	7.809	8.239	11.540
225	13.115	7.217	9.480
226	6.507	10.706	11.710
227	4.035	14.873	8.382
228	14.663	16.396	8.295
229	10.957	9.745	7.174
230	13.139	18.744	5.492
231	11.834	11.529	5.898
232	12.752	13.951	5.309
233	8.394	8.014	8.750
234	12.885	27.991	5.417
235	6.729	8.967	10.341
236	10.190	10.953	8.295
237	26.762	16.533	6.032
238	14.062	14.998	6.422
239	13.386	9.494	8.382
240	11.912	20.756	6.474
241	13.413	18.000	8.043
242	9.755	9.809	12.639
243	6.640	11.110	19.422
244	17.871	11.150	8.750
245	19.177	17.905	6.924
246	21.714	11.418	8.471
247	4.921	5.308	18.959
248	8.019	8.019	11.375
249	10.867	12.097	8.750
250	9.960	12.411	9.368
251	7.454	6.610	13.970
252	12.782	11.337	7.584
253	13.741	25.793	7.373
254	10.781	12.100	10.080
255	6.464	6.250	13.970
256	13.647	22.912	7.963
257	12.972	8.741	13.729
258	13.304	13.905	10.617
260	6.005	3.632	24.898
270	9.431	6.415	15.068
280	14.246	7.391	11.156
290	10.847	8.204	10.752
300	12.588	7.026	12.986
310	21.019	13.570	10.316
320	12.645	5.383	15.790
330	14.396	12.438	13.527

340	8.071	5.989	16.220
350	11.127	6.334	15.081
360	14.185	7.170	10.393
370	14.406	8.015	12.407
380	12.546	7.335	10.632
390	5.538	3.951	26.371
400	4.226	5.123	24.318
410	11.859	7.906	10.096
420	9.283	6.814	14.680
430	5.134	3.738	34.714
440	11.886	10.814	16.694
450	5.419	3.888	23.333
460	9.923	6.501	14.926
470	11.018	6.068	21.529
480	12.622	4.512	20.657
490	4.186	4.568	28.879
500	12.762	9.662	17.978
510	6.934	5.365	17.008
520	8.096	6.064	20.086
530	15.782	9.848	14.645
540	8.360	6.349	15.278
550	9.609	13.985	14.496
560	15.908	15.854	10.749
570	16.476	14.520	9.011
580	12.335	10.969	17.339
590	16.389	10.443	14.639
600	8.679	3.668	25.418
610	10.504	11.823	15.054
620	7.686	5.708	15.401
630	11.699	9.945	13.936
640	9.394	7.385	12.102
650	8.641	7.266	13.649
660	5.147	6.420	24.133
670	10.500	7.525	19.637
680	5.899	5.443	16.740
690	11.646	7.234	17.254
700	7.315	4.102	24.787
710	20.112	5.407	23.588
720	7.770	2.583	68.821
730	4.549	6.102	49.537
740	3.487	4.105	74.168
750	5.608	3.872	30.909
760	3.231	4.666	24.081
770	7.055	4.718	23.472
780	9.058	5.052	36.278
790	8.240	7.505	21.753
800	9.705	4.202	29.687
810	10.111	10.224	18.353
820	10.725	11.547	15.085
830	13.357	12.610	15.337
840	7.370	6.775	26.837
850	8.788	4.528	22.722
860	6.852	8.163	22.084

870	10.045	8.069	14.374
880	7.056	7.056	23.909
890	9.935	7.108	15.566
900	8.285	4.498	24.177
910	7.471	5.942	24.695
920	10.427	7.085	15.555
930	83.906	14.703	14.461
940	14.034	8.285	21.931
950	20.491	9.025	18.007
960	17.326	10.957	22.342
970	13.099	10.088	14.597
980	9.927	7.120	22.223
990	15.436	5.756	23.764
1000	11.128	5.875	25.312
1010	8.934	5.790	31.958
1020	14.139	5.598	28.424
1030	7.726	3.159	40.426
1040	13.438	4.366	34.025
1050	12.553	3.194	34.428
1060	20.506	5.870	20.650
1070	5.595	3.223	34.696
1080	6.305	3.470	32.598
1090	7.968	6.390	32.455
1100	9.792	9.514	11.071
1110	10.004	5.325	15.847
1120	17.597	8.054	16.677
1130	16.327	8.679	12.671
1140	23.271	8.588	10.428
1150	10.912	5.540	14.980
1160	8.490	5.469	20.250
1170	10.175	4.211	19.562
1180	9.854	6.773	16.048
1190	15.427	10.767	10.995
1200	55.145	10.278	12.856
1210	11.495	4.431	21.696
1220	13.186	4.636	20.536
1230	23.027	12.315	11.417
1240	7.945	4.747	19.853
1250	19.740	10.518	14.867
1260	12.242	6.846	22.508
1270	16.123	10.157	15.716
1280	12.524	6.904	12.918
1290	14.368	5.578	17.021
1300	10.559	3.583	25.982
1310	8.321	11.487	13.421
1320	12.836	7.841	20.740
1330	15.849	10.231	13.727
1340	14.013	11.172	13.014
1350	18.286	9.131	12.547
1360	9.794	4.942	20.195
1370	11.634	5.776	23.892
1380	9.975	3.726	28.364
1390	13.429	8.453	17.730

1400	8.423	7.334	24.723
1410	11.832	6.333	19.392
1420	5.719	5.469	33.033
1430	15.598	8.610	17.820
1440	7.639	4.463	25.811
1450	10.007	5.672	20.948
1460	10.216	6.066	20.657
1470	7.441	5.346	29.859
1480	38.719	12.659	12.731
1490	15.110	13.443	11.441
1500	15.453	7.204	12.881
1510	9.255	5.450	17.259
1520	22.341	7.366	13.259
1530	17.859	10.047	11.145
1540	11.766	12.660	11.056
1550	15.502	10.655	11.832
1560	23.361	11.015	14.840
1570	12.000	8.829	19.120
1580	16.733	9.917	12.782
1590	24.856	8.650	14.758
1600	20.929	10.446	10.616
1610	24.382	10.715	13.913
1620	13.658	7.647	16.677
1630	27.832	7.793	15.013
1640	15.107	5.058	24.282
1650	15.240	7.583	16.173
1660	9.587	4.911	25.217
1670	16.256	5.645	22.179
1680	10.434	5.404	23.621
1690	20.190	11.801	15.783
1700	16.985	14.257	14.288
1710	18.762	6.351	22.877
1720	16.314	9.970	20.682
1730	14.882	10.098	17.165
1740	9.748	7.070	19.978
1750	18.362	7.462	19.978
1760	16.568	8.525	16.275
1770	25.735	11.713	15.716
1780	17.243	10.324	17.425
1790	25.735	9.560	14.950
1800	21.279	6.938	19.900
1810	18.866	8.871	15.555
1820	30.486	10.303	14.176
1830	10.831	5.824	23.680
1840	24.130	11.531	17.317
1850	32.220	12.879	14.294
1860	14.236	11.589	19.104
1870	20.762	8.586	16.339
1880	21.271	9.771	16.665
1890	20.983	13.964	15.581
1900	21.163	7.062	20.562
1910	33.354	13.330	15.764
1920	22.529	11.792	16.974

1930	24.196	6.926	22.676
1940	15.450	8.283	21.161
1950	21.298	9.241	20.863
1960	15.847	7.984	22.120
1970	16.708	9.300	23.456
1980	18.155	10.785	19.308
1990	27.439	10.340	15.537
2000	20.660	10.024	22.622
2010	20.151	10.621	21.446
2020	19.490	11.485	21.439
2030	24.855	12.918	17.507
2040	44.388	15.294	16.339
2050	44.719	11.430	15.010
2060	23.496	10.559	22.194
2070	31.536	10.387	22.231
2080	19.094	8.239	22.327
2090	27.660	13.077	16.411
2100	24.789	9.566	18.995
2110	20.502	10.019	21.982
2120	23.006	13.403	19.314
2130	26.375	11.497	17.590
2140	21.260	11.135	16.307
2150	25.100	10.565	16.871
2160	28.372	14.285	15.444
2170	28.702	12.349	14.853
2180	25.367	15.240	16.694
2190	28.563	18.720	14.251
2200	17.094	10.119	25.633
2210	29.791	16.614	14.607
2220	27.706	10.307	18.218
2230	28.496	13.667	15.376
2240	35.033	15.256	13.341
2250	19.134	9.728	21.838
2260	23.721	16.005	17.272
2270	24.485	11.318	17.530
2280	23.678	10.983	17.303
2290	22.605	11.817	18.364
2300	30.133	12.917	15.064
2310	27.029	11.162	17.420
2320	25.156	14.553	17.916
2330	22.827	14.063	19.465
2340	26.014	14.991	17.834
2350	23.838	19.029	14.543
2360	28.934	14.879	14.635
2370	26.372	16.091	16.615
2380	30.514	18.837	13.971
2390	24.486	16.397	17.294
2400	23.373	16.356	17.416
2410	28.109	14.547	15.588
2420	33.236	19.531	13.093
2430	28.522	16.096	17.697
2440	34.712	16.634	12.623
2450	30.599	18.734	15.274

2460	25.800	17.529	16.196
2470	29.656	18.546	13.815
2480	32.854	16.769	13.065
2490	27.569	17.346	15.156
2500	31.357	17.022	13.238
2510	27.330	17.652	15.922
2520	27.369	18.414	15.790
2530	28.882	19.299	14.963
2540	26.054	13.548	16.935
2550	27.661	17.956	16.064
2560	32.971	20.663	12.844
2570	26.677	14.958	16.656
2580	25.225	13.706	17.740
2590	27.060	18.437	15.862
2600	26.859	18.006	15.661
2610	33.792	18.068	14.039
2620	26.937	14.877	17.223
2630	28.366	14.507	15.888
2640	28.266	13.289	17.716
2650	23.302	17.373	19.765
2660	27.276	15.803	18.506
2670	30.123	16.711	18.374
2680	25.276	16.762	19.812
2690	23.274	14.628	19.364
2700	33.492	24.340	15.316
2710	31.739	24.597	15.292
2720	30.819	17.004	15.994
2730	23.347	15.845	20.473
2740	31.319	22.923	15.617
2750	31.017	13.442	20.342
2760	31.151	19.499	16.467
2770	24.898	17.809	19.494
2780	28.714	17.870	17.721
2790	33.242	22.629	15.687
2800	33.293	19.662	15.926